

PRODUCT NUMBER

SEE TABLE

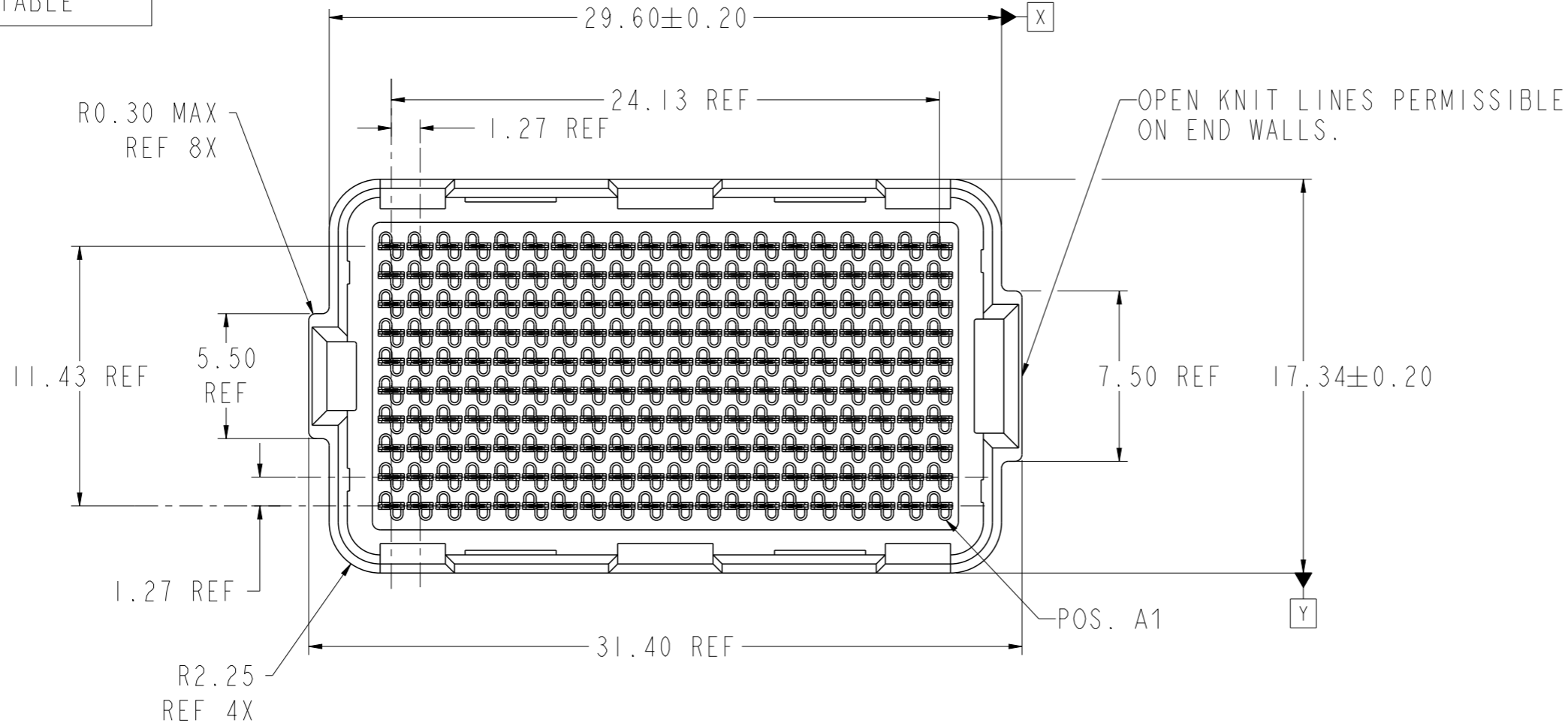

PROTECTIVE PICK-UP CAP

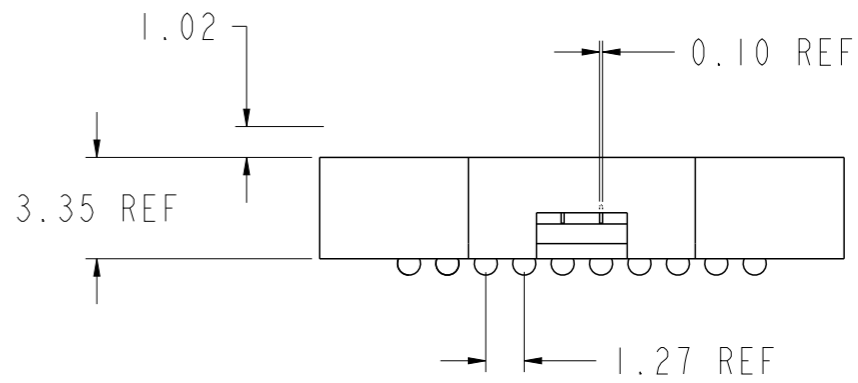
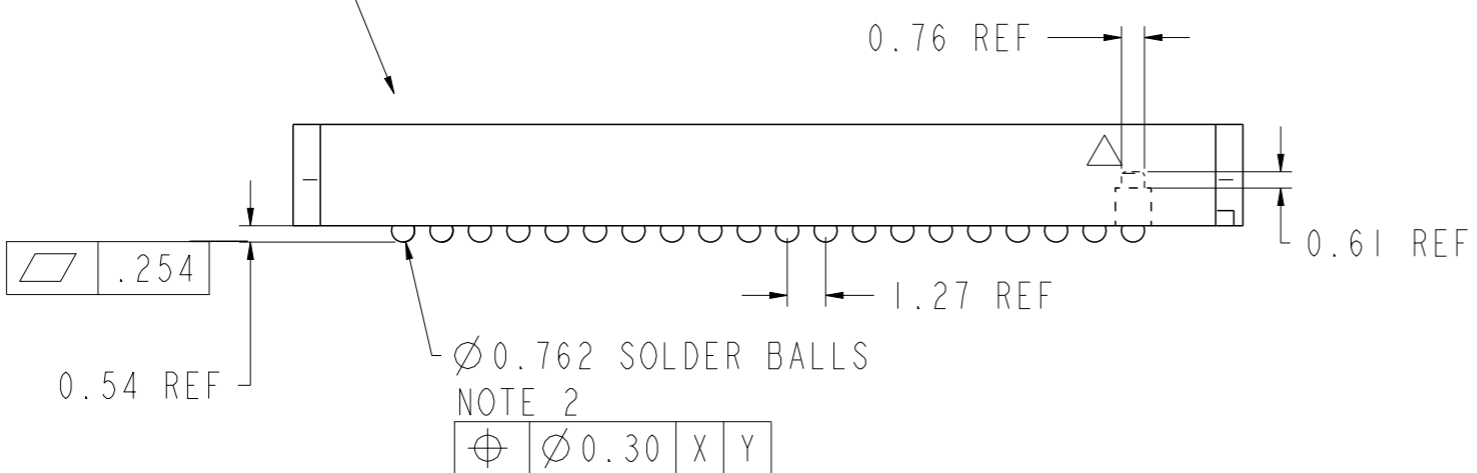

Copyright FCI.

spec ref	-	dr	wcadmin	2001/11/16	projection	mm	size	A3	scale	4:1
tolerance std	ASME Y14.5	eng	Dave Horchler	2012/11/21			ecn no	ELX-V-13512-1		
		chr	-				rel level	Released		
surface	✓	appr	R Marshall	2012/11/26	product family	MEG-ARRAY		cat	Released	
		linear	0.X	$\pm 0.3$		0mm PLUG ASSEMBLY		dwg no	84516	
			0.XX	$\pm 0.10$		10 x 20 = 200 POSITIONS		rev	H	
		angular	0°	$\pm 2^\circ$		cat. no.	Product - Customer Drw		sheet 1 of 5	

PRODUCT NUMBER

SEE TABLE

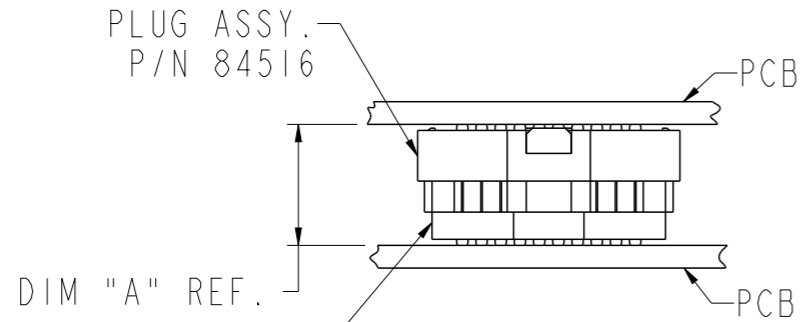

DIM "A" REF.  
MATED HEIGHT  
AFTER REFLOW  
SEE NOTE 3

**END VIEW - MATED CONNECTORS**

MATED HEIGHT AFTER REFLOW IS BASED ON  $\varnothing 0.64$ mm PAD (METAL DEFINED) AND 0.13mm SOLDER PASTE STENCIL THICKNESS. SEE NOTE 3.

RECPT. ASSY.  
(SEE TABLE BELOW)

STENCIL MATED CONNECTOR  
OUTLINE ONTO BOARD.

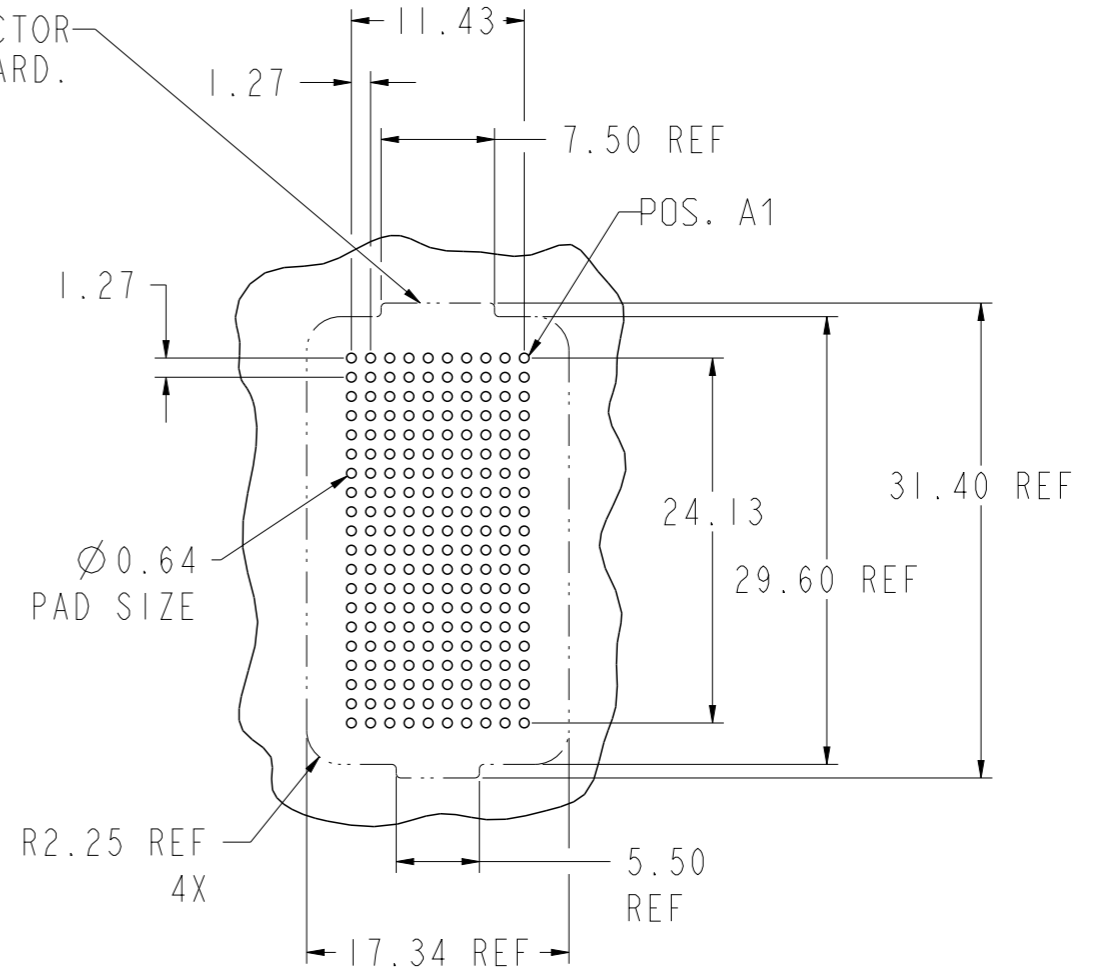

**BOARD PATTERN**

MATED HEIGHT TABLE

DIM "A"	RECPT. ASSY. P/N	-2XX PLATING
4.0	84517	SEE NOTE 4
6.0	55724	SEE NOTE 5
8.0	84535	SEE NOTE 5



Copyright FCI.

spec ref	-	dr	wcadmin	2001/11/16	projection	mm	size	A3	scale	10:1
tolerance std	ASME Y14.5	eng	Dave Horchler	2012/11/21			ecn no	ELX-V-13512-1		
		chr	-				rel level	ct	Released	
surface	✓	appr	R Marshall	2012/11/26	product family	MEG-ARRAY	dwg no	84516	rev	H
ASME Y14.5	angular	0°	±2°	www.fci.com	cat. no.	Product - Customer Drw	sheet 2 of 5			

PRODUCT NUMBER

SEE TABLE

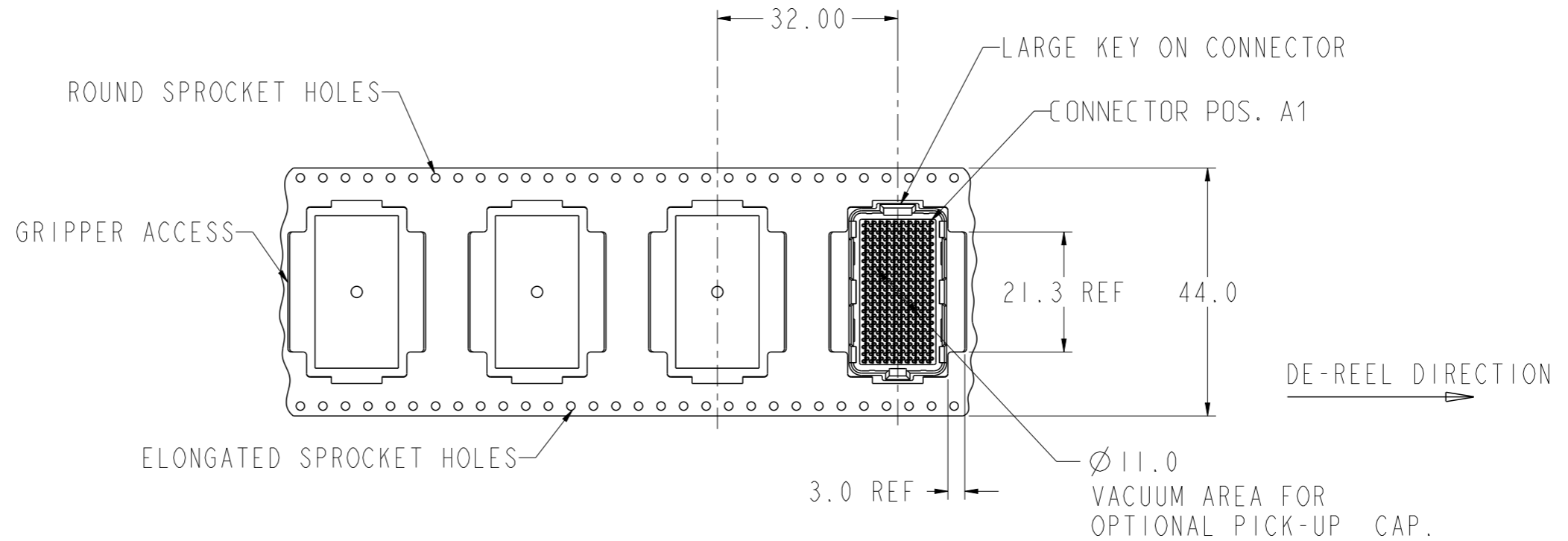

**TAPE & REEL PACKAGING**

PER EIA 481-3



Copyright FCI.

spec ref -		dr w wadmin	2001/11/16	projection	mm	size A3	scale 1:1
tolerance std ASME Y14.5	TOLERANCES UNLESS OTHERWISE SPECIFIED		eng Dave Horchler	2012/11/21	← →	ecn no	ELX-V-13512-1
			chr -	-		rel level	Released
surface ✓	linear	0.X ±0.3	appr R Marshall	2012/11/26	product family MEG-ARRAY	rel level	Released
		0.XX ±0.10			title 0mm PLUG ASSEMBLY 10 x 20 = 200 POSITIONS		rev
		0.XXX ±0.050					cat. no.
ASME Y14.5	angular	0° ±2°	www.fci.com		cat. no.	Product - Customer Drw	sheet 3 of 5

PRODUCT NUMBER	PICK-UP CAP (NATURAL OR BLACK COLOR)	CONTACT PLATING AND THICKNESS	SOLDER BALL	NOTES
84516-002	YES	15μ" / (.38μm) Au	SnPb	9
84516-002LF	YES	15μ" / (.38μm) Au	LEAD FREE	7 AND 9
84516-092	YES	15μ" / (.38μm) GXT		
84516-092LF	YES	15μ" / (.38μm) GXT		
84516-102	YES	30μ" / (.76μm) Au	SnPb	9
84516-102LF	YES	30μ" / (.76μm) Au	LEAD FREE	7 AND 9
84516-192	YES	30μ" / (.76μm) GXT	SnPb	4, 5 AND 9
84516-192LF	YES	30μ" / (.76μm) GXT		
84516-202	YES	50μ" / (1.27μm) Au SPECIAL		
84516-202LF	YES	50μ" / (1.27μm) Au SPECIAL	LEAD FREE	4, 5, 7 AND 9
84516-292	YES	50μ" / (1.27μm) GXT SPECIAL		
84516-292LF	YES	50μ" / (1.27μm) GXT SPECIAL		
84516-A02	YES	30μ" / (.76μm) SPECIAL	SnPb	8
84516-A02LF	YES	30μ" / (.76μm) SPECIAL	LEAD FREE	7 AND 8
<del>84516-302</del>	<del>YES</del>	<del>15μ" / (.38μm) Au SPECIAL</del>	<del>SnPb</del>	<del>8</del>
<del>84516-302LF</del>	<del>YES</del>	<del>15μ" / (.38μm) Au SPECIAL</del>	<del>LEAD FREE</del>	<del>7 AND 8</del>
<del>84516-402</del>	<del>YES</del>	<del>30μ" / (.76μm) Au SPECIAL</del>	<del>SnPb</del>	<del>8</del>
<del>84516-402LF</del>	<del>YES</del>	<del>30μ" / (.76μm) Au SPECIAL</del>	<del>LEAD FREE</del>	<del>7 AND 8</del>
<del>84516-502</del>	<del>YES</del>	<del>Au SPECIAL</del>	<del>SnPb</del>	<del>4, 5 AND 8</del>
<del>84516-502LF</del>	<del>YES</del>	<del>Au SPECIAL</del>	<del>LEAD FREE</del>	<del>4, 5, 7 AND 8</del>

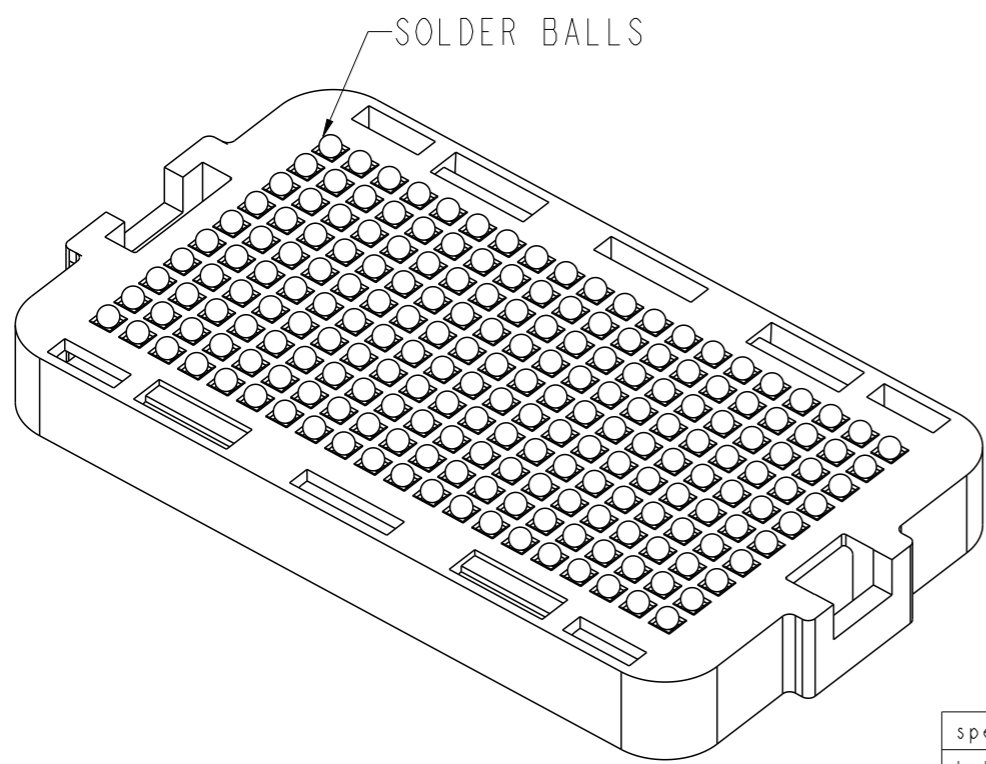

BOTTOM VIEW  
SCALE 4:1

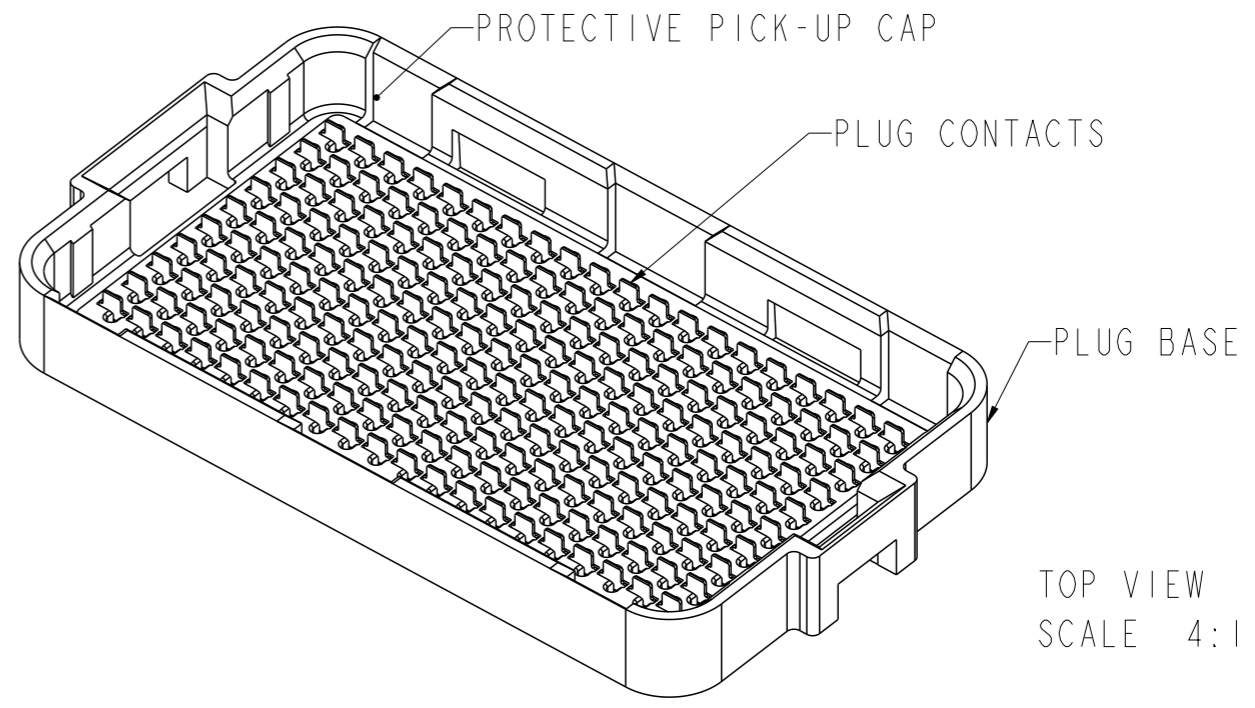

TOP VIEW  
SCALE 4:1

spec ref	-	dr	wcadmin	2001/11/16	projection	mm	size	A3	scale	1:1		
tolerance std	ASME Y14.5	eng	Dave Horchler	2012/11/21			ecn no	ELX-V-13512-1	rel level	Released		
TOLERANCES UNLESS OTHERWISE SPECIFIED		chr	-	apppr							R Marshall	2012/11/26
surface	✓	linear	0.X	±0.3		title 0mm PLUG ASSEMBLY 10 x 20 = 200 POSITIONS	dwg no 84516	rev H	Product - Customer Drw			
		angular	0°	±2°					www.fci.com	cat. no.	sheet 4 of 5	



Copyright FCI.

PRODUCT NUMBER

SEE TABLE

NOTES:

1. MATERIAL:  
HOUSING: LCP  
CONTACT: COPPER ALLOY

PLATING CONTACT: SEE TABLE ON SHEET 4  
SOLDER BALL: SEE TABLE ON SHEET 4  
EUTECTIC SnPb OR LEAD FREE  
95.5Sn/4Ag/0.5Cu

2. SOLDER BALLS WILL NOT BE PERFECT  
SPHERICAL SHAPE DUE TO REFLOW  
ATTACHMENT.

3. MATED HEIGHT EFFECTED BY CUSTOMER'S  
PCB PAD SIZE, PLATING, SOLDER REFLOW  
PROFILE & SOLDER PASTE.

4. PLATING FOR INDICATED -2XX SERIES PRODUCT NUMBERS  
MEET THE REQUIREMENTS OF  
GR-1217-CORE, CENTRAL OFFICE ENVIRONMENT,  
(25 YEAR LIFE EXPECTANCY).

5. PLATING FOR INDICATED -2XX SERIES PART NOS.  
IS Au OVER Ni WITH SPECIAL CONTACT  
GEOMETRY TO MEET REQUIREMENTS OF  
TELCORDIA GR-1217-CORE: CENTRAL OFFICE ENVIRONMENT.

6. FOR PROPER APPLICATION FOLLOW FCI APPLICATION SPECIFICATION  
GS-20-033. LEAD FREE SOLDER BALLS WILL NOT SOLDER PROPERLY  
IN A LEADED SOLDER PROSESS DUE TO A HIGHER REFLOW TEMPERATURE  
LEAD FREE PRODUCT IS THEREFORE NOT BACKWARDS COMPATIBLE WITH  
LEADED OR SOME SOLDERING APPLICATIONS. REFERENCE FCI  
APPLICATION SPECIFICATION.

7. THIS PRODUCT MEETS EUROPEAN UNION DIRECTIVE AND OTHER  
COUNTRY REGULATIONS AS DESCRIBED IN GS-47-0004. PRODUCT  
MEETING THIS DIRECTIVE IS IDENTIFIED IN THE LOT CODE  
NUMBER MARKED ON EACH PART BY HAVING AN "X" IN THE SEVENTH  
CHARACTER POSITION.

8. 84516-A02 AND -A02LF PLATING IS CUSTOMER SPECIAL.

10. A  SYMBOL WILL BE NEXT TO ANY DIMENSION, NEW VIEW, OR NOTE  
WHICH HAS BEEN MODIFIED WITH THE CURRENT DRAWING REVISION.

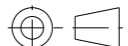
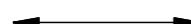

Copyright FCI.

spec ref	-	dr	w wadmin	2001/11/16	projection	mm	size	A3	scale	2:1
tolerance std	ASME Y14.5	eng	Dave Horchler	2012/11/21			ecn no		ELX-V-13512-1	
	TOLERANCES UNLESS OTHERWISE SPECIFIED	chr	-	-			rel level		Released	
surface	✓	appr	R Marshall	2012/11/26	product family	MEG-ARRAY	cat		Released	
	linear	FCI		0mm PLUG ASSEMBLY		dwg no	84516		rev	
	ASME Y14.5	angular	0°	±2°	www.fci.com	cat. no.	Product - Customer Drw		sheet 5 of 5	