



# SIM231 TECHNICAL REFERENCE MANUAL



## IMPORTANT LEGAL NOTICE

See the latest and complete warranty, licensing and legal information at [www.seriousintegrated.com/legal](http://www.seriousintegrated.com/legal).

Information herein is provided in connection with Serious Integrated, Inc. ("SERIOUS") products.

The products may comprise components designed and manufactured by SERIOUS as well as other vendors. This information may refer to a variety of specifications related to those non-SERIOUS components for informational purposes only, and the user is strongly urged to consult the original manufacturers' data sheets and other documentation for authoritative specifications.

No license, express or implied, by estoppel or otherwise, to any intellectual property rights is granted by this information.

SERIOUS assumes no liability whatsoever, and SERIOUS disclaims any warranties whether express or implied, written, oral, statutory or otherwise relating to the information and its use, including any liability for warranties relating to fitness for a particular purpose, performance, quality, merchantability, or infringement of any patent, copyright or other intellectual property right. The user is responsible for determining the suitability of SERIOUS products for the intended application and that applicable specifications are met.

SERIOUS makes no representations or warranties with respect to the accuracy or completeness of the information and may make changes to the information, specifications and product descriptions at any time without notice. Designers should not rely on the absence or characteristics of any features or instructions marked "reserved" or "undefined." SERIOUS reserves these for future definition and shall have no responsibility whatsoever for conflicts or incompatibilities arising from future changes to such features or instructions. SERIOUS products may contain design defects or errors known as errata which may cause the product to deviate from published specifications. Current characterized errata are available upon request.

Use of SERIOUS products in automotive, military, aircraft, space, life-saving or life-sustaining applications or in any systems where failure or malfunction may result in personal injury, death or severe property or environmental damage is entirely at the buyer's risk and the buyer agrees to defend, indemnify and hold harmless SERIOUS from any and all damages, claims, suits or expenses resulting from such use.

## TRADEMARKS AND COPYRIGHTS

The "Serious" name and stylized Serious mark are trademarks of Serious Integrated, Inc. The information herein, unless otherwise indicated, is Copyright 2013-2014 Serious Integrated, Inc.

Third party brands and names are the property of their respective owners.

**CONTENTS**

IMPORTANT LEGAL NOTICE .....2

TRADEMARKS AND COPYRIGHTS .....2

Document Information and Applicable Products .....6

    Change History and Applicable Products .....6

    Document Conventions .....6

Introduction .....7

    Usage Models.....7

    Hardware.....8

    Software .....8

    Getting started .....9

Ordering Information..... 10

    Order Codes ..... 10

    Variant Options ..... 11

    LCD Options..... 12

    Development Kits..... 13

Specifications..... 14

    DC Maximum Ratings ..... 14

    DC Operating Characteristics ..... 14

        Module Level ..... 14

        By Subsystem ..... 15

        MCU I/O..... 15

    AC Timing Characteristics..... 15

    Environmental Characteristics..... 16

    Handling and Care ..... 16

        Handling..... 16

        Pressure and Impact..... 17

        Storage..... 17

        Cleaning..... 17

    Physical Characteristics..... 18

        Alignment and Mounting Holes..... 18

        LCD Dimensions and Bezel Size ..... 19

        Module Weight..... 19

- Daughter Card Physical Guidelines ..... 20
- Serious Communications Modules ..... 22
- Hardware Overview ..... 23
  - High Performance Renesas RX63N/631 MCU..... 23
  - Graphic Color LCD Display and Touch Option..... 23
  - Serious Gatling™ Technology ..... 24
  - On-Module Peripherals..... 24
  - On-Module Memory..... 24
  - Communications and Connectors ..... 24
  - Power..... 25
- Module Feature Detail ..... 26
  - Renesas RX63N/RX631 MCU..... 26
    - MCU Boot Modes and the USB Boot FLASH..... 26
  - LCD Display ..... 28
    - Graphics Controller..... 28
    - Touch Controller ..... 28
    - Proximity Sensing..... 29
    - Ambient Light Sensing..... 29
  - Power Supplies ..... 30
    - Power Input: **+VIN\_MAIN** ..... 30
    - Power Input: **+VEXT** ..... 30
    - Turning SIM231 Off: **PWRDWN#**..... 30
    - +3.3V (**+3V3**) Regulation..... 31
    - +5V\_USBF**:USB Device (“Function”) Power ..... 31
    - +5V\_USBH**: USB Host Power..... 31
    - LCD Panel Backlight Power: **P11-BLEN** and **BL\_LED+/BL\_LED-** ..... 32
    - Battery Backed Real Time Clock/Calendar (RTCC): **+VBAT** ..... 32
  - Memory..... 33
    - Serial FLASH..... 33
    - SDRAM..... 34
    - EEPROM ..... 34
  - Serious Serial Number..... 34
  - Cryptographic/Authentication device ..... 35
  - Clocks, Oscillators, and Time Keeping..... 36

High Speed (12 MHz) Clock..... 36

MCU Real-Time Clock/Calendar (RTCC)..... 36

External RTCC with Optional Battery Backup ..... 36

Audio ..... 37

    Piezo Sounder ..... 37

10-bit Single Channel DAC..... 38

User LED ..... 38

I2C Device Summary..... 38

Interrupt Summary ..... 38

Connectors ..... 39

    SHIP Programming Port..... 39

    Tag-Connect JTAG Port..... 40

    16-pin Power/Communications Connector..... 40

    USB Micro B Device Connector ..... 41

    USB A Host Connector..... 42

    60-pin Expansion Connector ..... 42

Universal Serial Bus (USB) ..... 44

    Device IDs ..... 44

    USB Software ..... 45

    USB2.0 Full-Speed Device Port ..... 45

    USB2.0 Full Speed Embedded Host Port ..... 45

Additional Information..... 46

## DOCUMENT INFORMATION AND APPLICABLE PRODUCTS

### CHANGE HISTORY AND APPLICABLE PRODUCTS

The following table summarizes major changes to this document and the applicable versions of the product corresponding to this document:

Doc Version	Date	For HW Versions	Major Changes
A0	23 Sep 13	1.0	<ul style="list-style-type: none"> <li>▶ Initial prerelease version</li> </ul>
A1	27 Sep 13	1.0	<ul style="list-style-type: none"> <li>▶ First internal scrub; alpha customer ready</li> </ul>
B0	20 Jan 14	2.0	<ul style="list-style-type: none"> <li>▶ Updated for pre-production v2.0 units                             <ul style="list-style-type: none"> <li>▶ Removed PCB Edge connector</li> <li>▶ Added Tag-Connect for JTAG</li> <li>▶ Added new SHIP Programming Port</li> <li>▶ Removed haptic option</li> <li>▶ Finalized LCD specification for initial MVA LCD options</li> <li>▶ Added LCD 24-bit support notes</li> <li>▶ USB device connector changed from mini to micro</li> </ul> </li> <li>▶ Added references to SCM117</li> </ul>
B1	19 Jun 14	2.0	<ul style="list-style-type: none"> <li>▶ Moved BLEN from P11 to P24 for production; PWM capable</li> <li>▶ Added Dev Kit description/section</li> <li>▶ Added Care and Handling section</li> <li>▶ Expanded Daughter Card guidelines</li> <li>▶ Expanded Physical Characteristics and mechanical guidelines</li> <li>▶ Updated/Clarified daughter card mirror pin-out</li> <li>▶ Added backlight power, next rev will have full power characterization data</li> </ul>

### DOCUMENT CONVENTIONS



This symbol indicates an advanced tip for hardware or software designers to extract interesting or unique value from the Serious Integrated Module.



Pay special attention to this note – items especially subject to change, or related to compatibility, functionality, and usage.



**WARNING: You can damage your board, damage attached systems, overheat or cause things to catch fire if you do not heed these warnings.**



Notes with this symbol are related to license and associated legal issues you need to understand to use this software. We're big believers in honoring license agreements, so please help the industry by respecting intellectual property ownership.



Some hardware features may be preconfigured or permanently reserved for use by the [SHIPEngine](#) software (the GUI management engine component of the [Serious Human Interface™ Platform](#)). Notes with this symbol indicate where the module comes pre-configured or uses these resources.

**INTRODUCTION**

The SIM231 family of *Serious Integrated Modules* is a series of complete intelligent 3.5" QVGA graphic front panels, some with resistive touch capability.

The SIM231 family incorporates *Serious Gatling™ Technology* for rapid-fire delivery of pixels to the display with minimal CPU overhead while retaining the cost-effective elements of a solution without a dedicated hardware graphics controller. Using this technology, the SIM231 can deliver 16 or 24 bit color frames to the LCD with little CPU and SDRAM bandwidth required.



These cost-effective modules are designed for use by Original Equipment Manufacturers (OEMs), custom design shops, and hobbyists to add sophisticated and user-friendly graphical user interfaces to their products.

**USAGE MODELS**

In most cases, you will be adding a SIM to a system that already has an MCU, I/O, power conditioning, and other custom interfaces. Perhaps your system already has a membrane keypad and a 2x16 character display or indicator LEDs. Your current MCU software in your existing system controller manages all aspects of your device, including (as applicable) belts, pumps, motors, servos, indicators, etc.

Rather than completely redesigning the hardware and software of your existing system to create a merged hardware/software architecture (LCD front panel plus system controller all-in-one), it is far more common to partition the problem by retaining your existing system controller and software and using the SIM as an intelligent stand-alone front panel.

Therefore SIMs typically most often used as stand-alone front panels responsible for managing just the Human Machine Interface (HMI) in a larger system. The existing, separate, device-specific system controller continues to manage the main functionality of the system. SIMs are equipped with several methods for simple interconnect to the external system controller, getting power from that external system, and communicating via a serial type link (SPI, UART, USB) to that controller to exchange data and commands.

Using the *Serious Human Interface™ Platform (SHIP)*, the software team can leverage the power of the *SHIPTide* rapid GUI development tools from *Serious*, developing a user interface in as little as a few hours and a few dozen lines of code. The *SHIPEngine* runtime firmware pre-installed on all SIMs takes care of all the drivers, rendering, communications, and event handling for the user interface, leaving the GUI development process to be focused on look and feel and differentiation of your device. You never need to write C code or use a JTAG debugger with a SIM to develop a modern-looking user interface.



SHIP software and development tools are available at no-cost for users of Serious Integrated Modules. See [www.seriousintegrated.com/SHIP](http://www.seriousintegrated.com/SHIP) for details.

Adding a simple software protocol driver to your system controller on the other end of the communications link allows your controller to communicate with the front panel. You can then architect inter-board messages such as “pump is on” which could be sent over the UART/SPI/etc. causing visual indicators to appear or change on the display. A GUI on the SIM231 could change user preferences, for instance, sending back messages such as “pump on days: MWF” which the system controller may store in its configuration EEPROM.

The possibilities are endless: the SIM231 module contains not only a powerful MCU but also a suite of hardware features that are commonly needed in many designs. An alarm panel, for example, could be as simple as a SIM231 connected to another PCB with a \$0.20 MCU, a few relays and a battery.

## HARDWARE

SIM231 family features include:

- 4.3" WQVGA 480x272 [color TFT display](#)
  - Various touch panel options, including 4-wire resistive with proximity detection
  - Color depths from 16 to 24-bit
  - [Serious Gatling™ Technology](#) for rapid-fire pixel delivery to the LCD with minimal CPU intervention
- 100MHz 32-bit [Renesas RX631/RX63N MCU](#)
  - 128KB RAM, 512KB-2MB FLASH
  - Integrated temp sensor & RTCC
  - Ethernet RMII available on expansion connector on some variants
- On-module memory
  - 8-16MB [SDRAM](#)
  - 8-16MB [serial FLASH](#) + [4kbit EEPROM](#)
- Extensive I/O
  - [60-pin Expansion Connector](#) (GPIO, +5V, RESET#, I2C, SPI, UART; RMII on 63N-based units)
  - *Serious* system-to-system [16-pin Power/Communications Connector](#)
  - [SHIP Programming Port](#) for rapid GUI/Firmware programming
  - [USB Micro B Device Connector](#)
  - [USB A Host Connector](#)
  - [Tag-Connect JTAG Port](#)
- PCB operating temperatures as wide as -40 to 85°C; [LCD option](#) may restrict operating range.

Within the SIM231 are numerous family members, or “variants”. Each variant has a slightly different set of features and price points for an OEM to select the appropriate feature/cost point for their specific application. Consult the [Variant Table](#) for more information. In addition to these different functional variants, various [LCD options](#) are available.

## SOFTWARE

Developing a complete graphic user interface (GUI) can be a complex, time consuming, and expensive endeavor. Often tens of thousands of lines of custom C code need to be developed in conjunction with custom hardware drivers and off-the-shelf libraries. For rapid GUI development, the [Serious Human Interface™ Platform](#) offers PC-based GUI design tools and rapid GUI prototyping, development, and deployment. With minimal coding you can create attractive and functional GUIs in a fraction of the time of C-based development.



SHIP software and development tools are available at no-cost for users of Serious Integrated Modules. See [www.seriousintegrated.com/SHIP](http://www.seriousintegrated.com/SHIP) for details.

The SIM231 is also supported by a growing collection of Renesas, open source, as well as *Serious* proprietary software, allowing designers to gain confidence that their essential software can not only get it done, but perform to the needed end result. Available at [mySerious.com](http://mySerious.com) for download, SIM231 programmers can obtain an out-of-the-box experience with pre-ported versions of the [Micrium uCOS-III](#), [Segger embOS](#) and [FreeRTOS](#) operating systems. The SIM231 includes full single-unit production licenses of the Micrium and Segger kernels for use with each module.

It is very difficult to know, as a designer selecting the hardware for a graphic/touch interface, if the result after many months of software and graphic design will have acceptable performance. Will the system be responsive? Will it be visually



attractive? Will the look-and-feel be consistent with the company's brand image? *Serious* addresses these OEM designer challenges by delivering video best-of-class GUI examples, fostering community demos and solutions, and providing software, tools, and consulting services.

## GETTING STARTED

The SIM231 comes pre-configured with a SHIP demo loaded into the in the RX MCU and serial FLASH.

If your SIM variant has a USB Micro B connector present, your SIM can be powered from any PC's USB port or USB hub with 500mA power capability.

Alternatively if you have purchased a development kit containing a [SHIP Programming Adapter 200 \(SPA200\)](#) and [SHIP Programming Connector SPC200](#), you can plug the SPA200/SPC200 combination into the [SHIP Programming Port](#) with the SPA200 powered from a PC USB port, hub, or even a stand-alone USB AC power adapter.



Several connectors may be used to power the SIM231. See [Power Supplies](#).

The demo will start running and displaying info on the LCD screen. For more getting started information and out-of-the-box tips, see [www.seriousintegrated.com/oob](http://www.seriousintegrated.com/oob).

**ORDERING INFORMATION**

Consult an [authorized Serious representative](#) for an up-to-date listing of order codes, family variants, and LCD options available.



This document version contains prerelease information prior to product introduction and is subject to change.

**ORDER CODES**

SIM order codes are constructed as follows:

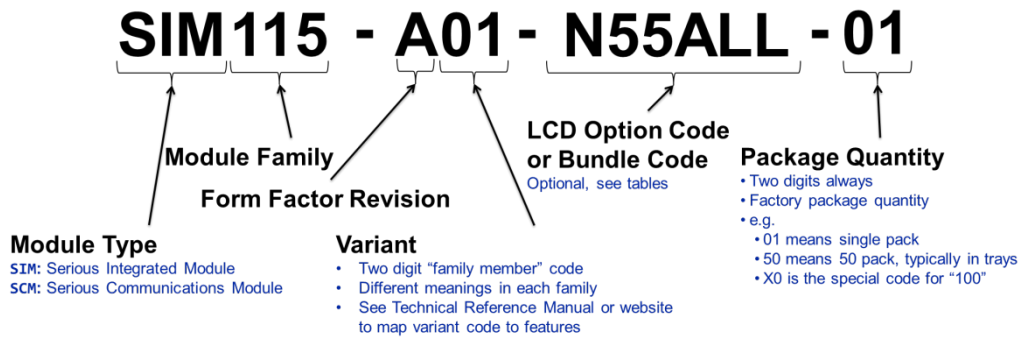

As of the time of this document's publish date, the current order codes are as follows:

Order Code	Description	Detail	Pkg Qty
SIM231-A01-DEV-01	Dev Kit SIM231-A01-R32ALM w/SPA200-A00, Cables, Acrylic Case	Includes SHIP Programming Adapter kit. No JTAG debugger/adaptor included.	1
SIM231-A01-R32ALM-01	Color Graphic LCD Module	RX63N 768/128, 16MB DRAM, 16MB	1
SIM231-A01-R32ALM-10	4.3" WQVGA w/Serious Gatling™ Technology	SFLASH, USB Device+Host, Piezo, RTCC,	10
SIM231-A01-R32ALM-50	Res Touch, Full Featured	Prox, AmbLight	50
SIM231-A02-N32ALM-01	Color Graphic LCD Module	RX63N 768/128, 16MB DRAM, 16MB	1
SIM231-A02-N32ALM-10	4.3" WQVGA w/Serious Gatling™ Technology	SFLASH, USB Device+Host, Piezo, RTCC,	10
SIM231-A02-N32ALM-50	No Touch, Full Featured	AmbLight	50
SIM231-A03-R32ALM-01	Color Graphic LCD Module	RX631 512/128, 8MB DRAM, 8MB	1
SIM231-A03-R32ALM-10	4.3" WQVGA w/Serious Gatling™ Technology	SFLASH, Prox, AmbLight	10
SIM231-A03-R32ALM-50	Res Touch, Low Cost		50
SIM231-A04-N32ALM-01	Color Graphic LCD Module	RX631 512/128, 8MB DRAM, 8MB	1
SIM231-A04-N32ALM-10	4.3" WQVGA w/Serious Gatling™ Technology	SFLASH, AmbLight	10
SIM231-A04-N32ALM-50	No Touch, Low Cost		50

For a detailed explanation of LCD Option Codes, consult the [Serious website](#).

**VARIANT OPTIONS**

As of the time of this document’s publish date, the variants (aka family members) are:

Family Variant	A01	A02	A03	A04
<b>MCU</b>				
MCU	RX63N	RX63N	RX631	RX631
MCU Max MHz	100	100	100	100
MCU FLASH/RAM(kB)	768/128	768/128	512/128	512/128
JTAG E1 Debug	⊙⊙	⊙⊙	⊙⊙	⊙⊙
<b>Memory</b>				
SDRAM (MB)	16	16	8	8
Serial FLASH (MB)	2x8	2x8	8	8
EEPROM	✓	✓	✓	✓
<b>LCD &amp; Touch</b>				
<i>Serious</i> Gatling™ Technology	✓	✓	✓	✓
Touch	R4		R4	
Capacitive Proximity Sensor	✓		✓	
Ambient Light Sensor	✓	✓	✓	✓
<b>Peripherals &amp; GPIO</b>				
User Red/Green/Orange LED	✓	✓		
PCB Temp Sensor	✓	✓		
Piezo Sounder	✓	✓		
32.768kHz Clock/Calendar	PCF8523	PCF8523	MCU	MCU
USB 2.0 FS device circuitry	So	So	So	So
USB 2.0 FS host circuitry	So	So		
<b>Expansion Connectors</b>				
USB 2.0 FS device Micro-B connector	✓	✓		
USB 2.0 FS host A connector	✓	✓		
60-pin Board-to-Board Expansion Connector Power, I2C, SPI, UART, DAC, RMII (w/RX63N)	✓	✓	✓	✓
16-pin <i>Serious</i> Power/Comms Connector Power, I2C, SPI, UART	✓	✓	✓	✓
<b>Power</b>				
Power Input (5V typical)	⊙⊙S	⊙⊙S	⊙⊙S	⊙⊙S
CR1025 coin cell holder for RTCC backup	✓	✓		

- ⊙ on [16-pin Power/Communications Connector](#)
- on [60-pin Expansion Connector](#)
- ⊙ on [Tag-Connect JTAG Port](#)
- S on [SHIP Programming Port](#)
- So on [USB A Host Connector](#)
- So on [USB Micro B Device Connector](#)



This table contains prerelease information prior to product introduction and is subject to change.

## LCD OPTIONS

Consult the following table for available LCD Options on the SIM231 family at the time of this document release. Not all LCD options are available for all variants: for an up-to-date list, contact an [authorized Serious representative](#). For a detailed explanation of LCD Option Codes, consult the [Serious website](#).

LCD Option Code Serial Number Byte <sup>1</sup>	R32ALM 0x00	N32ALM 0x00
Size (diagonal, active, inches)	4.3	4.3
Size (diagonal, active, inches)	4.3	4.3
Resolution	480x272	480x272
Touch	R4	
NITs (min typ)	300+	300+
Backlight Life (min typ, hours)	20k	20k
Viewing Technology	Multi-Viewing Angle (MVA)	Multi-Viewing Angle (MVA)
Viewing Angles (min typ)	75°	75°
Proximity Detect Capable	✓	
Color Depth (bits)	16/24	16/24
Operating Temp Range	-20 <sup>2</sup> to +70C <sup>3</sup>	-20 <sup>3</sup> to +70 <sup>3</sup> C
Storage Temp Range	-30 to +80C	-30 to +80C
On-glass RAM	0	0
Active Area (mm W x mm W)	95.04 x 53.86	95.04 x 53.86
Pixel Pitch (µm W x µm H)	198 x 198	198 x 198
Backlight Power (min typ/max typ @100%, mW)	640/660 <sup>4</sup>	640/660 <sup>4</sup>

Notes: <sup>1</sup>See [Serious Serial Number](#)

<sup>2</sup>LCD will become slightly sluggish at low temperatures below -10C

<sup>2</sup>LCD will become darker near the high end of the temperature range

<sup>4</sup>LCD power at the backlight; SIM boost converter inefficiencies increase this at a module level; see [DC Operating Characteristics](#)

Note that the PCB, MCU, and associated components may be rated for a larger operating temperature range than the LCD. In this case, the MCU will operate correctly over the entire operating range however the LCD may not function or be visible outside its specified operating range. In all cases, the narrower of the two recommended storage temperature ranges (PCB and LCD) should not be exceeded.

## DEVELOPMENT KITS

The [SIM231-A01-DEV-01](#) development kit contains everything needed to develop with, and production program, all members of the SIM231 family.



Some variants of the SIM231, such as the SIM231-A03 and –A04, have no USB device connector populated – **you must have a SPA200** (included in the development kit) **to be able to program and update these modules.**



The SIM231 is primarily intended for GUI development with the [Serious Human Interface™ Platform](#) therefore the standard development kit has no JTAG debugger included. To develop in C, you must purchase separately:

- a JTAG debugger, such as a [Segger J-Link](#) with [J-Link RX Adapter](#) or Renesas E1
- a [Tag-Connect TC2070](#) adapter cable and retention clips

The kit contains:

- [SIM231-A01-R32ALM](#) module
  - Superset of all SIM231 features
  - Bright 300+ NIT Resistive Touch Multi Viewing Angle LCD with proximity and ambient light detection
- [SHIP Programming Adapter 200 \(SPA200\) Kit](#)
  - [SHIP Programming Adapter 200 \(SPA200\)](#) intelligent rapid-programming unit for development and high-volume production use
  - [SHIP Programming Connector 200 \(SPC200\)](#) to connect the SPA200 to all newer SIMs, including [SIM115](#), [SIM231](#), and [SIM535](#)
  - All cables necessary to connect the PC to the SPA200, the SPA200 to SPC200, and SPC200 to the SIM
  - 5V 12W wall power supply for lab use (110/220VAC EU/US voltage and plug compatibility) powers the SPA and optionally powers the SIM as well
- 16 pin wire harness (JST16 plug one end, tinned the other) for lab cable enabling
- Acrylic “enclosure” for safe handling and demonstration use



The [SPA200](#) and [SPC200](#) are set for release in Q3 2014; Development kits shipped prior to this release will include a mail-in coupon for these.



This is a preliminary table (prior to product release) and is subject to change.

**SPECIFICATIONS**

**DC MAXIMUM RATINGS**

The following are absolute maximum limits for the specified variants:

Specification	Variant	DC Limits			
		Min	Typ	Max	Units
Input Supply Voltage +VEXT	A01	4.50 <sup>1</sup>	5.00	5.25	V
	A02	4.50 <sup>1</sup>	5.00	5.25	V
	A01	3.60 <sup>2</sup>	5.00	5.25	V
	A02	3.60 <sup>2</sup>	5.00	5.25	V
	A03	3.60	5.00	5.50	V
	A04	3.60	5.00	5.50	V

Notes: <sup>1</sup>USB Host circuit enabled  
<sup>2</sup>USB Host circuit never enabled

**DC OPERATING CHARACTERISTICS**

**MODULE LEVEL**

The following DC characteristics apply to all variants of the SIM231:

Specification	LCD Backlight State	USB Host Boost	Range				Units
			Typ <sup>1,2,5</sup>	Typ <sup>1,3,5</sup>	Max <sup>1,2</sup>	Max <sup>1,3</sup>	
Input Supply Current +VEXT	RESET		<i>tbd</i>	<i>tbd</i>	<i>tbd</i>	<i>tbd</i>	mW
	off	off	<i>tbd</i>	<i>tbd</i>	<i>tbd</i>	<i>tbd</i>	mW
	100%	off	<i>tbd</i>	<i>tbd</i>	<i>tbd</i>	<i>tbd</i>	mW
	100%	on <sup>4</sup>	<i>tbd</i>	<i>tbd</i>	<i>tbd</i>	<i>tbd</i>	mW

Notes: <sup>1</sup>Any additional external current draw from the module is in addition to this value  
<sup>2</sup>At minimum voltage on supply  
<sup>3</sup>At typical input supply voltage  
<sup>4</sup>No device inserted; device power is in addition to this number plus typical conversion loss of 10-20%.  
*Numbers in this style are preliminary and pending final characterization.*

BY SUBSYSTEM

The amount of power necessary for SIM231 to function is highly dependent on how and which features of the module you use. This is especially true for major power consumers such as the LCD backlight and USB embedded host port. If your application does not enable these features, the typical and maximum power numbers can be appropriately subtracted from the maximums for the SIM respectively. Assuming typical switching conversion efficiency, the power breakdown of the elements is as follows:

Subsystem	Circuit-Local Power Required (mW) <sup>1</sup>			+VEXT to Local Conversion Efficiency (typ)	+VEXT Power Required (mW) <sup>1</sup>		
	Min	Typ	Max		Min	Typ	Max
LCD Backlight							
N32ALM/R32ALM LCD options		640	660	80%	800	825	
LCD Logic		<i>tbd</i> <sup>3</sup>	<i>tbd</i> <sup>4</sup>	92%	<i>tbd</i> <sup>3</sup>	<i>tbd</i> <sup>4</sup>	
Serious Gatling™ Technology		66	100	92%	72	108	
Piezo		3	10	92%	4	11	
MCU		178	370	92%	194	402	
DRAM 8MB or 16MB		200	594	92%	217	645	
SFLASH 8MB or 16MB		33	83	92%	36	90	
Resistive Touch		33	56	92%	36	61	
USB Host		0 <sup>2</sup>	750	85%	0 <sup>2</sup>	883	
Other logic and miscellaneous		<i>tbd</i>	<i>tbd</i>	92%	<i>tbd</i>	<i>tbd</i>	

- Notes: <sup>1</sup>At typical input supply voltage  
<sup>2</sup>No device inserted; device power is in addition to this number.  
<sup>3</sup>50% white/50% black or 50% RGB pixel intensity  
<sup>4</sup>100% white  
*Numbers in this style are preliminary and pending final characterization.*

MCU I/O

Many I/O signals on the SIM231 are directly and exclusively connected to [RX63N/631](#) MCU pins. Consult the [RX63N/631](#) data sheet for complete specifications of each pin.

 There are specific power limitations on the MCU pins. Consult the [RX63N/631](#) data sheet for more information. **Exceeding these limits may damage your board, damage attached systems, overheat or cause things to catch fire.**

AC TIMING CHARACTERISTICS

The AC timing characteristics at the module level are governed by the underlying AC timing characteristics of the individual components. Consult the component data sheets for more information.



The no-cost SHIPWare source code as well as the full-featured [Serious Human Interface™ Platform](#) software initializes the MCU and other SIM components for correct operation.

**ENVIRONMENTAL CHARACTERISTICS**

The following table describes the absolute maximum environmental conditions for the SIM231:

Specification	Variant	Permissible Range			Units
		Min	Typ	Max	
Operating Temperature (not including LCD)	All	-40		+85	C
Storage Temperature (not including LCD)	All	-40		+85	C
Humidity	All			90% below 50C 60% above 50C	RH



Note that these limits do not include the LCD environmental limits. For example, while the SIM may be able to function over its full operating temperature range, often the LCD temperature range is more restrictive and the LCD may become difficult to read, sluggish, or non-functional outside its limits.

Consult the [LCD Options](#) to determine the operating and storage temperature limits for the LCD selected. In no case should the unit be stored outside the narrower of the Storage Temperature ranges of the SIM and its LCD.

**HANDLING AND CARE**

Observe the following handling and care guidelines.

**HANDLING**



Be very careful when handling the edge of the SIM where the flexible cable from the LCD panel is exposed. This can be easily damaged or ripped if shear-force is applied in handling.



Do not attempt to disassemble the module or solder components or wires to the module; this may render your board non-functional and void your warranty.



As with all electronic subsystems and circuits, observe proper ESD handling procedures.



As with any glass product, use reasonable care when handling to avoid glass chips and cracks.



If the LCD glass breaks and the LCD liquid materials escape, avoid contact with bare skin. Wash exposed skin with soap and water immediately and dispose of the product according to local materials handling procedures.





If the SIM comes in factory packaging with a protective cover sheet on the LCD, it is advised to leave this protective film in place until the SIM is mounted in the final assembly to prevent scratches and fingerprints from marring the display surface. Do not expose to high temperature and/or high humidity testing with the protective sheet place. Slowly remove the protective sheet to minimize potential static electricity creation.



---

## PRESSURE AND IMPACT

-  On non-touch variants apply no pressure, and ensure no impact can be made by end users, to the surface of the LCD display. There is no specification for pressure or impact on non-touch LCDs.
-  On touch variants, do not use sharp objects to activate the touch screen or the overlay material may be damaged.
-  Do not apply any bending/twisting force to the LCD or the SIM PCB or the unit may be permanently damaged.

---

## STORAGE

Follow these basic precautions when storing un-installed SIMs for extended periods:

1. Store SIMs in the original factory packaging whenever possible. The sealed polyethylene antistatic bags or the antistatic trays are designed for long term storage.
2. Store the SIM sub-packs where they will not be subjected to high heat, sunlight, or high humidity conditions. Recommended storage temperatures should be kept between 0C and +40C, with relative humidity below 80%.
3. Desiccant should not be required if properly sealed and room temperature ambient temperatures are maintained.

---

## CLEANING

If cleaning of the LCD panel surface is necessary, Isopropyl or Ethyl alcohol, either 100% or mixed 50%/50% with distilled water, may be used on a moist clean soft cloth.

-  Do not use abrasive, ketone-containing, and aromatic solvents which will damage polarizer materials.

**PHYSICAL CHARACTERISTICS**

The outer dimensions of the SIM231 are approximately 121.6mm x 67.3mm. Note that for those variants with USB Micro B and/or USB A connectors populated, these connectors extend approximately 2mm beyond this width. The depth of the module depends on the variant. For example, variants with resistive touch screens have the cover glass and touch layer on the LCD that increase depth by over 1mm. Also, various connectors such as the USB A connector, if populated, change the mechanical dimensions. An example of the SIM231-A01-R32ALM module dimensions are shown here:

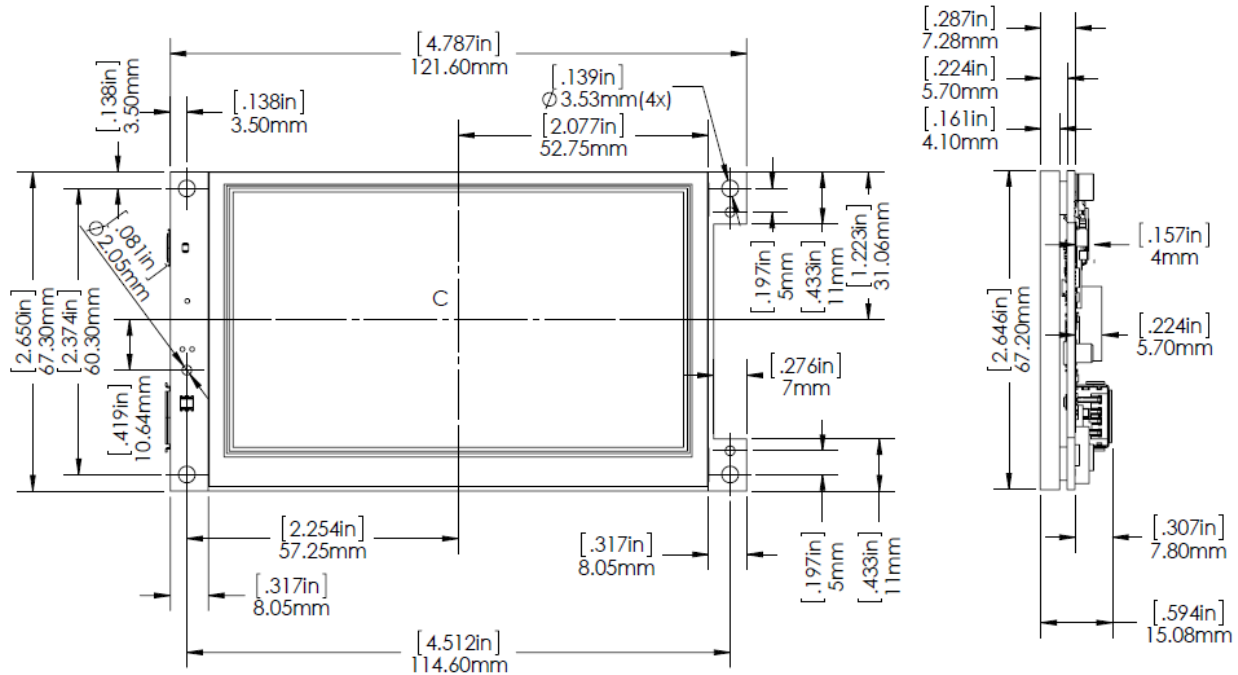

Dimensional drawings and complete 3D STEP models are available for most SIMs, including the SIM231. Visit [www.seriousintegrated.com/docs](http://www.seriousintegrated.com/docs) for more information.

**ALIGNMENT AND MOUNTING HOLES**

There are four (4) 3.50mm holes by which the SIM should be attached into a chassis. Four M2.5, M3 or similar screws into correctly-sized standoffs from the inside of the bezel assembly will be more than adequate to firmly hold the module. The holes are over-sized from the typical screw in order to allow tolerance for standoff positioning as well as to ensure the module can be arranged to perfectly center in the bezel's opening.

Rather than attempt to tighten the screws while manually/visually positioning the module in the bezel opening, all SIMs include reference alignment holes to ensure perfect alignment within your bezel. Locate the several 2.05mm holes on the mechanical diagram – any two of these are meant to accommodate simple non-threaded alignment pins precisely positioned on the inside of your bezel. The SIM can be initially inserted onto the two precision alignment pins, thereby centering and positioning the active area of the LCD in your bezel, and then the four mounting screws can be inserted and tightened.

If your chassis is molded plastic, you can extrude very slightly tapered pins for this purpose. For metal bezels, off-the-shelf pins such as the [PEM Engineering MPP series](#) of self-clinching pins can be used. Depending on the tolerance of your insertion process of the pins into the metal bezel, you may want to undersize these pins to 1mm or 1.5mm, recognizing that the tolerance will slightly affect the consistency of the LCD positioning.

LCD DIMENSIONS AND BEZEL SIZE

The LCD glass positioning is a critical element for correct location of the display within a bezel. This positioning is well-defined in the Mechanical Design Package (MDP) for the specific variant, and should always be referenced relative to the center of the active pixel area of the display. Note in the diagram above the “C” designator which *does not* indicate the physical center of the LCD module or the SIM, but rather the center of the *active pixel area of the LCD display*. The MDP also shows a diagram similar to the following (from the SIM231-A01-R32ALM MDP):

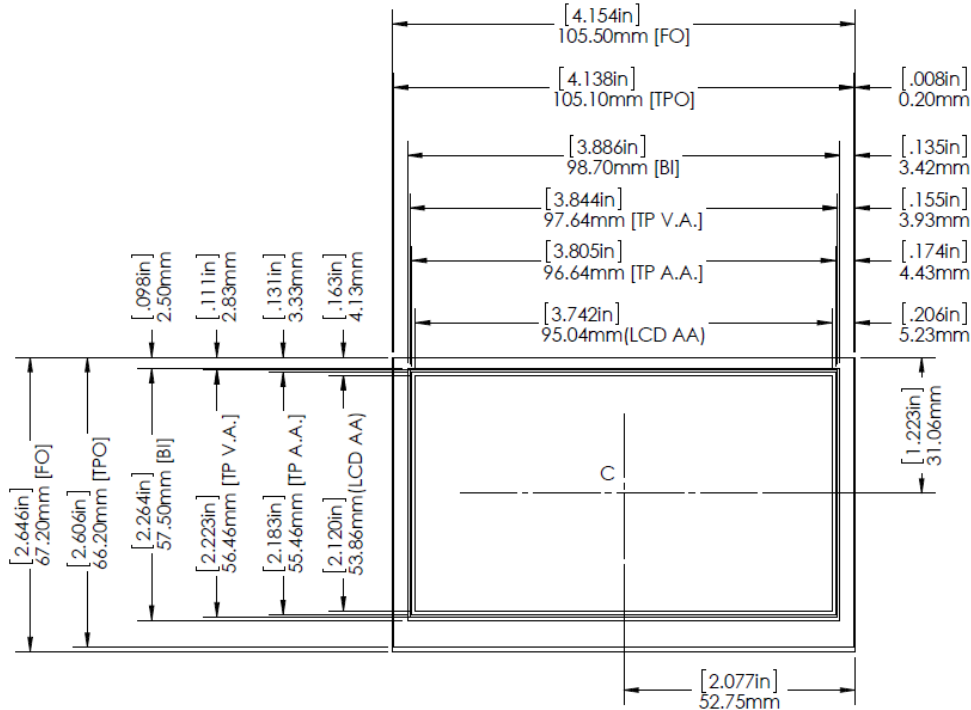

These two diagrams are critical for correct bezel design. The acronyms in the above LCD diagram are as follows:

- ▶ **FO: Frame Outer** -- outer dimensions of the physical LCD display module
- ▶ **TPO: Touch Panel Outer** –outer limits of the resistive touch panel material
- ▶ **BI: Bezel Inner** –inner limit where your bezel should be contacting the surface of the touch panel & LCD display with any gasket and not adversely affect touch performance
- ▶ **TP V.A.: Touch Panel Visual Area** – conductors from the touch panel are no longer visible inside this area; your bezel will extend and cover to this dimension
- ▶ **TP A.A. Touch Panel Active Area** –start of the active area of the touch panel, which may extend slightly outside the active area of the pixels
- ▶ **LCD AA: LCD Active Area** -- active pixel area of the LCD display; you will want to ensure visually the center (C) of this active area is centered in your bezel opening and that all the active area is visible to the end user

MODULE WEIGHT

The weight of the module is as follows, excluding any external cable harnesses, daughter cards, or batteries:

Variant	Permissible Range		
	Typ	Max	Units
A01	<i>tbd</i>	<i>tbd</i>	g
A02	<i>tbd</i>	<i>tbd</i>	g
A03	<i>tbd</i>	<i>tbd</i>	g
A04	<i>tbd</i>	<i>tbd</i>	g

**DAUGHTER CARD PHYSICAL GUIDELINES**



This section is provided as a helpful overview only. The authoritative mechanical reference is the SIM535 Mechanical Design Package (MDP), which includes 2D drawings and STEP models, and is available for download at [www.seriousintegrated.com/docs](http://www.seriousintegrated.com/docs).

Most new SIMs across most of their variants include a [60-Pin Board-to-Board Expansion Connector](#). These variants also include six M3 threaded standoffs ([PennEngineering® SMTSO-M3-4-ET](#) or similar) to firmly support and attach a daughter card at the correct 4mm board-to-board distance.



*Serious* reserves the right to substitute components and/or change component layout on SIMs at any time without notice. Exceeding the height envelope described below with the assumption of specific SIM component used and/or placement so as to utilize the inner-stack-height for daughter card components may cause mechanical conflicts in future SIM revisions.



It is possible to create a single daughter card that can dock into numerous SIMs, including the SIM115, SIM231, and SIM535. Consult the respective Technical Reference Manuals (TRMs) to validate a compatible footprint: there are slight differences in the physical and electrical characteristic for daughter cards across different SIMs.

The board-to-board distance with this connector (when used with an identical mated connector) is only 4mm, enabling a daughter card to be developed with a very low overall combined profile. For components on the side of the daughter card facing the SIM, observe the maximum component height zones on the SIM – your components may extend only 4mm *less this distance* on the SIM-facing side of your PCB:

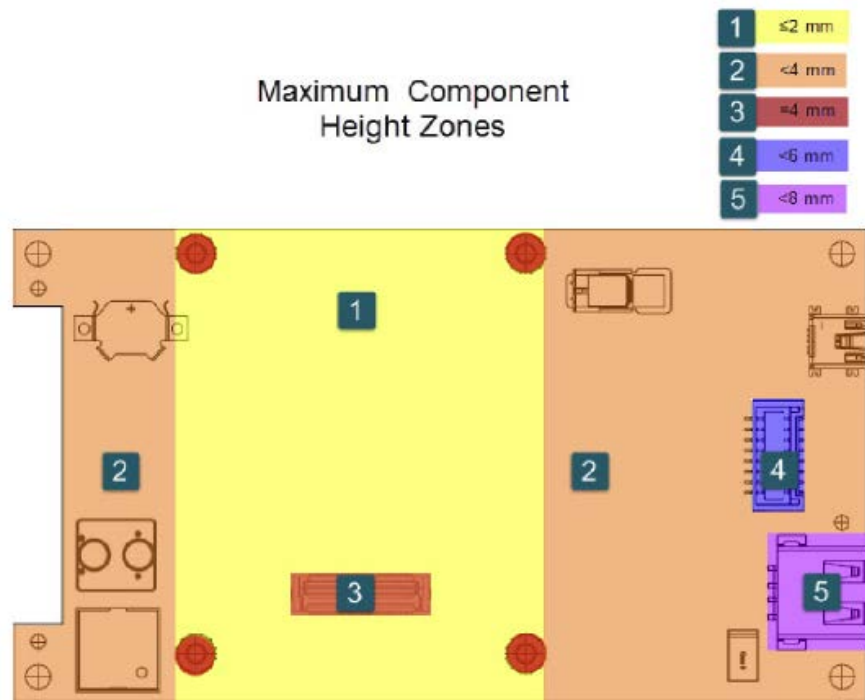

*Example SIM231-A01-R32ALM Max Height Zone Map*

For example, in the yellow shaded area above, the components on the SIM535 are less than 2mm total height, leaving (4mm board-to board) minus (2mm yellow height zone) = 2mm for components on the SIM-facing side of a daughter card.



Note that component data sheets typically indicate the physical height of the component which is not necessarily the same as the total height of the component after soldering, which may slightly raise (or even lower, in the case of some BGAs) the component.

For prototyping, any M3-0.5x6mm pan head or cap socket screw can be used to attach a daughter card to the SIM. For production units, the recommended screw and assembly torque specifications for attaching a daughter card are as follows:

Parameter	Recommendation		
Material	Stainless A1-50 or better		
Size	M3-0.5 x 6mm		
Head	Cap Socket (hex) or Pan Head 6-lobe/5-lobe/Torx®		
Patch	Nylon Patch per Specification IFI-524 2002 <i>Test Procedure for the Performance of Metric Nonmetallic Resistant Element Prevailing Torque Screws</i>		
	Specification	N·m	inch·lbs
	Maximum Prevailing Torque:	0.60	5.31
	Minimum First Removal Prevailing Torque	0.14	1.24
Insertion Torque	*Recommended:	0.60 N·m (5.3 inch·lbs)	
	*Maximum:	0.70 N·m (6.2 inch·lbs)	

*\*subject to final production characterization*

Small quantities of this type of screw can be readily purchased from [McMaster-Carr \(93705A813\)](#). Production volumes are readily available from many suppliers, including part number .30C60MRPS/NPAT from [North State Fastener, Inc.](#)



Do not apply excessive torque to daughter card screws into the threaded standoffs or they may tear from the PCB and permanently damage the SIM.



Do not use screws longer than recommended or the screw may apply force to the back side of the LCD panel and permanently damage it.

**SERIOUS COMMUNICATIONS MODULES**

*Serious* is in the process of releasing several new communications daughter cards designed to dock into the back of the SIM115, SIM231, and SIM535 as well as some future SIMs.

The [Serious Communications/Power Module 117 \(SCM117\)](#) family, for example, is a series of flexible and production-worthy communications and power conversion accessory boards for use with Serious Integrated Modules (SIMs). The SCM117 can dock directly into newer SIMs such as the [SIM115](#), [SIM231](#), and [SIM535](#) forming a low profile and cost effective combination.

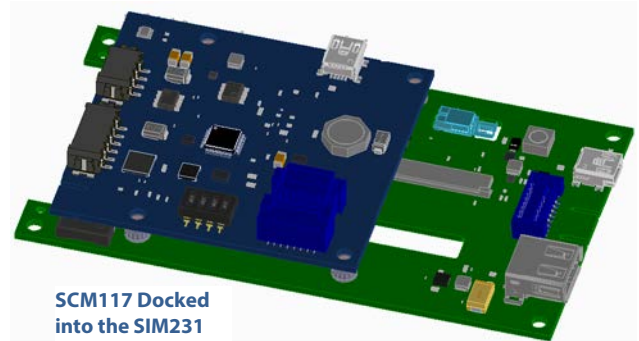

The SCM117 family has numerous members, or “variants”, implementing all or a subset of the following:

- › RS232, RS422, RS485, and CAN transceivers
- › Renesas RX111 MCU for local protocol translation and control
- › DC-DC converter for powering the SCM and attached SIM from network-borne power

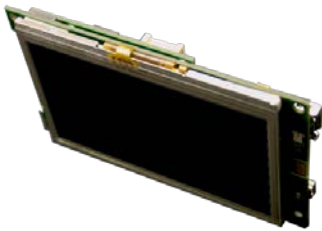

The SCM117’s most basic functionality is to provide network physical layer transceivers from the network cabling (RS232, RS485, RS422, or CAN) to the SIM, as well as network power conversion from whatever voltage (+9-25VDC) is available on the network cabling to the 5VDC required by the SIM and SCM.

Variants with the RX111 MCU place the RX111 in the middle of this conversation: the RX111 can communicate with the SIM using one protocol (for example, Modbus or the new *SHIP Bridge* protocol) and another protocol on the network (for example, your own proprietary protocol).

For more information on the SCM117, see the [Serious website](#).

**HARDWARE OVERVIEW**

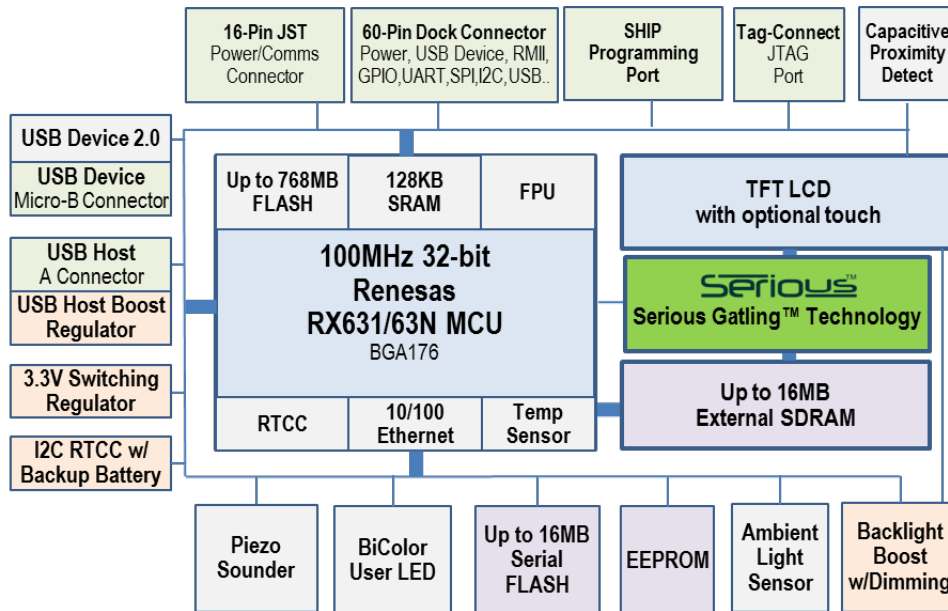

**SIM231 Hardware Block Diagram**  
options depend on variant selected

Not all features are available on all SIM231 variants (family members).

**HIGH PERFORMANCE RENESAS RX63N/631 MCU**

The heart of the SIM231 is the 32-bit Renesas [RX63N/631](#) microcontroller (MCU) with 128kB of internal RAM, and zero wait-state internal execution FLASH. This powerful MCU is equipped with extensive analog and digital peripherals and, with software, can deliver an excellent user interface experience.

**GRAPHIC COLOR LCD DISPLAY AND TOUCH OPTION**

The SIM231’s Liquid Crystal Display (“LCD” or “glass”) has an on-glass row-column driver chip for illuminating pixels but has no on-glass frame buffer or memory. The pixel data must be delivered at approximately 60Hz per complete frame by the MCU, and stored and managed in system DRAM.

The [RX63N/631](#) MCU does not include an on-board graphics controller; however the raw horsepower of this MCU family, when combined with its peripherals and *Serious Gatling™ Technology* on the SIM231 can deliver impressive user interfaces, including multi-layer alpha blending, animation, and more.

With a 480x272 pixel resolution at 16 bits of color information per pixel (in RGB565 format), each frame requires 130,560 bytes of RAM. For a double-buffered system, 261,120 bytes for the two frame buffers are required. *Serious Gatling Technology* delivers excellent performance in this mode: less than 17% of the SDRAM bandwidth is required to deliver the frame buffer to the LCD at 60Hz.

For color-sensitive applications, such as those with extensive gradients, the SIM231 also supports 24 bit color mode. When 24-bit color mode is enabled, twice as much DRAM is required per frame buffer, and SDRAM bandwidth required to deliver the frame buffer to the LCD at 60Hz is less than 33%.

Some SIM231 variants include an integrated 4-wire resistive touch feature: a resistive film over the LCD returns an analog voltage in two dimensions which can be read by the touch controller and translated with a ratio into a pixel hit position. These touch-enabled variants also include a capacitive proximity detection feature where the proximity of a bare finger will be detectable by sensors which can be read by software.

## SERIOUS GATLING™ TECHNOLOGY

Designed to assist the MCU's existing pixel to LCD connectivity, *Serious Gatling™ Technology* enables lower CPU overhead, increased throughput, and improved efficiency of rapid-fire pixel delivery from the CPU-Memory subsystem to the LCD display.

On the SIM231, the technology is implemented in an FPGA. The FPGA chip accommodates a fly-by-burst-mode DMA from the MCU into its internal pixel FIFO and delivers a fixed rate pixel stream to the LCD. It also manages all the timing to the LCD screen, delivering pixels at a rate determined by the FPGA configuration. This configuration (available from *Serious*) is downloaded at boot time through the RX MCU's SPI port.

The DMA unit on the RX MCU must be programmed to continuously deliver the current frame buffer as requested by the chip in a DREQ#/DACK# cycle using SDRAM continuous access single cycle mode.



The no-cost [Serious Human Interface™ Platform](#) software automatically initializes the FPGA and includes the correct driver for the SIM231's implementation of Serious Gatling Technology.

## ON-MODULE PERIPHERALS

The SIM231 contains numerous on-module peripherals – many common to a vast and diverse set of OEM applications, including a Real Time Clock/Calendar (RTCC) (battery-backed on some modules), USB device, USB host, serial FLASH, high speed UART(s), EEPROM, bi-color indicator LED, and more.

## ON-MODULE MEMORY

The SIM231 module has a variety of memory for storage of program, data, images, parameters, etc.:

### FLASH Memory:

- [Up to 16MB serial FLASH](#) memory attached via dedicated SPI (either 1 or 2 8MB chips)

### EEPROM

- Up to 4kbits [EEPROM](#)

### RAM

- 128kB RAM within the [RX63N/RX631](#) MCU
- Up to 16MBytes of [SDRAM](#)

## COMMUNICATIONS AND CONNECTORS

The SIM231 has numerous off-module communication ports and connectors. Some may or may not be available on specific SIM231 variants.

- [60-pin Board-to-Board Expansion Connector](#) with extensive I/O including:
  - DAC, SPI, I2C, CAN, and high-speed UART ports
  - USB device and host connections
  - Power input/output



- GPIO
- JTAG
- RMI (on variants with RX63N)
- [Tag-Connect JTAG Port](#) for MCU-level programming/debugging
- [SHIP Programming Port](#) for easy reprogramming of your *Serious Human Interface™ Platform* (SHIP) GUI or SHIPEngine during development or in an high-throughput production environment
- [USB Micro B Device Connector](#)
  - USB 2.0 full speed device port
- [USB Host Port](#)
  - USB 2.0 full speed embedded host port capable of supplying up to 150mA
- [16-pin Power/Communications Connector](#)
  - Suitable for an inexpensive wire harness with latching plug connection
  - 3.3V Tx/Rx UART, SPI, I2C, +5V in, +3V3 out, RESET#, and DAC output

## POWER

The SIM231 module can be powered from the **+V\_EXT** signal (typically 5V) available on several connectors:

- [16-pin Power/Communications Connector](#)
- [60-pin Expansion Connector](#)
- [SHIP Programming Port](#)

The SIM231 can also be powered via the **+5V\_USB** signal on the USB device port. Commonly during GUI development with SHIPTide the USB Micro B connector can be connected to an adequately powered USB port.

Alternatively, and especially for those variants without the USB Micro B connector, the [SHIP Programming Port](#) can supply 5V from a suitable USB port on a powered hub, PC port, or USB AC Adapter when used with a [SHIP Programming Adapter 200 \(SPA200\)](#) and the [SHIP Programming Connector SPC200](#).



The permissible input voltage range, by variant, is detailed in the [DC Maximum Ratings](#) section.

**MODULE FEATURE DETAIL**



*SIM231-A01 Component-side View*

**RENESAS [RX63N/RX631](#) MCU**

At the heart of the SIM231 is a 100MHz 32-bit Renesas [RX63N/RX631](#) MCU equipped with extensive analog and digital peripherals. Features include:

**MCU Core & Memory**

- ▶ 100MHz 32-bit core, typically operating at 96MHz on the SIM231
- ▶ 128kB zero wait state internal RAM
- ▶ Hardware Floating Point Unit (FPU)

**Peripherals include:**

- ▶ One USB 2.0 FS embedded host port and one USB 2.0 FS device port
- ▶ SDRAM controller
- ▶ DMA controller and Data Transfer Controller
- ▶ Multi-channel 10- and 12-bit A/D Converters
- ▶ Numerous SPI, I2C, CAN, and high-speed-capable serial ports

**MCU BOOT MODES AND THE USB BOOT FLASH**

Three separate FLASH memory areas are available inside the RX MCU: Program FLASH, Data FLASH, and USB Boot Mode FLASH as well as one Boot Mode ROM. Three “boot modes” are available on the RX631/RX63N MCU family based on the state of the **MD** and **PC7** pins when the **RESET#** signal is released. Depending on which of the three boot modes is determined at reset, the MCU jumps to a corresponding start address for code execution.

MD	PC7	Boot Mode	Execution start after RESET#
High	X	Normal Program Boot Mode	Program FLASH reset vector
Low	Low	ROM Boot Mode	Start of Boot Mode ROM
Low	High	USB Boot Mode	Start of USB Boot Mode FLASH

In normal Program boot mode, the **PC7** signal is completely available for program and system use. However, in the two special boot modes, **PC7** must remain fixed throughout the operation of the mode until the subsequent **RESET#** and is not available for general program and system use during these special modes.

The **MD1** and **PC7** signals are weakly pulled high on the SIM231, ensuring that for normal operation the MCU will boot in Normal Program Boot Mode, starting execution at the main RX MCU Program FLASH reset vector. The Program FLASH can

be (re)programmed in a variety of ways, including the JTAG port exposed on the [Tag-Connect JTAG Port](#) and [60-pin Expansion Connector](#).



The [Serious Human Interface™ Platform](#) v5 can update the RX MCU program FLASH over many different connections including USB, SPI, and UART using the built-in **Tug** bootloader and the **SHIP Bridge** protocol. This update can be performed from within the SHIPTide development environment: no JTAG debugger or C programming tools are required.

Because the **PC7** and **MD1** signals are available on the [Tag-Connect JTAG Port](#) and [60-pin Expansion Connector](#), they can be pulled low externally to the SIM forcing the SIM to go into one of the two special boot modes. Consult the Renesas [RX63N/RX631 MCU Hardware Manual](#) for additional boot mode details.

In USB Boot Mode, the processor begins execution in the 16KB USB Boot FLASH rather than the normal program FLASH. **Serious** programs the USB boot area with special firmware designed to function with the [Serious Human Interface™ Platform](#) tools, enabling reprogramming of the [SHIPEngine](#) and Serial FLASH with new GUI cargo files. The algorithm in this firmware is proprietary, and when the SIM231 boots in USB Boot mode the USB port will identify itself as requiring up to 500mA of bus power and having USB Vendor ID **0x25D8** (registered exclusively to *Serious*) and USB Product ID in the **0x0001** to **0x0099** range depending on the version of the protocol contained in the area.

#### FIRMWARE SHIPPED ON THE SIM231

The SIM231 comes with a pre-installed version of SHIPEngine v5.x, the runtime binary component of the Serious Human Interface™ Platform (SHIP).

SHIPEngine v5.x includes a complete boot loader (*Tug*) which includes upgrade and communications capabilities using the *SHIP Bridge* protocol. The boot loader and off-line upgrade system is installed in the top 8kB of the RX program FLASH as well as in the primary serial FLASH. The SHIPEngine v5 is contained in the remainder of the RX program FLASH. The GUI and configuration data, as in SHIP v4, is also contained in the remainder of the serial FLASH(s).



To use the full features of the [Serious Human Interface™ Platform](#), you need to preserve the *Serious* firmware in the RX program FLASH and serial FLASH(s). Modifying/erasing either the serial FLASH(s) or RX program FLASH will render the SHIPEngine and boot loader unusable. Restoring these images can be accomplished using [USB Boot mode](#) and SHIPTide/SHIPCrane tools available at [www.seriousintegrated.com](http://www.seriousintegrated.com).

#### REPROGRAMMING THE SERIAL FLASH

The on-SIM serial FLASH chip(s) can be re-programmed via software or with custom hardware by externally holding the SIM in RESET# and accessing the serial FLASH through the SPI bus present on these connectors:

- ▶ [60-pin Expansion Connector](#)
- ▶ [SHIP Programming Port](#)



The [Serious Human Interface™ Platform](#) v5 can update the serial FLASH(s) over many different connections including USB, SPI, and UART.

#### REPROGRAMMING THE RX MCU PROGRAM FLASH

The RX MCU program FLASH can be re-programmed from a JTAG debugger (such as the Renesas E1 or Segger L-Link) via the [Tag-Connect JTAG Port](#) using a Tag Connect TC2070 cable, available directly from [Tag-Connect.com](http://Tag-Connect.com) or [Digi-Key](#).



The [Serious Human Interface™ Platform](#) v5 can update the RX MCU program FLASH over many different connections including USB, SPI, and UART.

## LCD DISPLAY

The LCD display (or “glass”) on the SIM231 is a 4.3” diagonal active area 480x272 TFT with optional 4-wire resistive touch layer. The LCD display has no on-glass frame buffer or memory. The MCU, with the Serious Gatling Technology assistance, is responsible for delivering pixel data at a specific frequency to the LCD display as well as various clock signals otherwise the display will not function correctly and will not display a stable image. No valid image is possible unless the MCU is operating and, under software control, the MCU is delivering pixel and timing data to the LCD display continuously. The LCD display, in absence of a valid signal from the MCU, may automatically enter self-test mode and display various cycling test patterns.

The LCD backlight is enabled when **P24/MTIO04A-BLEN** is driven high, which turns on the backlight power boost circuit driving a constant current to flow through the backlight LEDs on the LCD. This enable signal has a weak pull-down, so the backlight is off until the MCU pin is initialized, including during and directly after system **RESET#**. This MCU pin is hardware pulse-width-modulation (PWM)-capable to enable 0-100% backlight dimming based on the duty cycle. A typical 1kHz PWM clock with 16 steps for a net frequency of 64 Hz is generally sufficient and flicker free with duty cycles from 0 to 100%. The PWM clock should not exceed 16kHz.



The [Serious Human Interface™ Platform](#) has the backlight driver included; setting the platform glass backlight value to 0 to 100% automatically modulates the dimming circuit.

---

## GRAPHICS CONTROLLER

Since the LCD display has no on-glass frame buffer, pixel data must be held in memory and streamed continuously to the display hardware. This memory must also be MCU accessible in order for software to “draw” into the frame buffers and transfer images and drawings to the screen.

On the SIM231, the [RX63N/631](#) has insufficient internal RAM to contain frame buffers: multiple frame buffers can be created in the external SDRAM. Typically, two frame buffers are used: one as the currently displaying frame, the other as a hidden frame where updates and drawing can happen. Then the two can be swapped (the display controller DMA channel pointed at the hidden buffer) to expose the new frame and allow the prior-displayed frame to be used as the new working buffer.

The [RX63N/631](#) is a high performance general purpose MCU capable of driving an LCD display with very little external logic. The SIM231 implements [Serious Gatling™ Technology](#): a combination of MCU-supported burst DMA and SDRAM with external logic delivering rapid-fire pixels to the LCD display with minimal MCU overhead. Depending on the configuration of the technology and the associated driver, the LCD can be operated in 16 bit or 24 bit color modes.



The no-cost SHIPWare software at [mySerious.com](#) includes all initialization code, drivers, and utilities to enable the basic functions of the graphics controller, including portrait and landscape modes and adjustable frame rates. This software is available after account sign-up and registration of your SIM231 serial number.



The [Serious Human Interface™ Platform](#) software system has fully-integrated and optimized drivers and frame buffer management, making the graphics controller details transparent to the GUI designer.

---

## TOUCH CONTROLLER

Some SIM231 family members include a resistive touch layer bonded to the LCD display. The layer can return an analog voltage in two dimensions to be read by analog-to-digital converters in the touch controller and translated with a software algorithm into a pixel hit position.

Resistive touch layers are made from a highly resilient Polyethylene Terephthalate (PET) film, and have the advantage of being robust and usable with a stylus, finger, or any blunt object. Unlike typical capacitive touch screens, resistive touch screens do not require the bare finger and can be used through gloves – important for certain medical, industrial, and

automotive applications. They also work well in wet conditions, although appropriate caution must be taken to ensure liquids do not flow onto the SIM231 or other circuitry. **Serious** application note [AN0201: Resistive Touch Bezel Guidelines](#) is a good resource for understanding how to mount a touch screen behind a bezel.

Some chemicals including (but not limited to) Ketone-based products, harsh cleansers, and abrasive cleaning products can discolor and/or damage the PET film. To ensure long usable lifetime, make sure end-users are well-informed on how to clean and maintain the touch screen.

The SIM231 employs a stand-alone 4-wire resistive [Semtech SX8656](#) touch controller with proximity sensing. The SX8656 provides sophisticated touch sensing/processing and delivers touch data back to the MCU via I2C. When touch data is available (for example, when the screen is pressed or a finger is dragged along the touch panel), the touch controller generates an interrupt on an MCU interrupt pin at which point software can read the device and determine the pixel coordinates and/or action.



See the [I2C Device Summary](#) for the complete table of I2C device addresses.



See the [Interrupt Summary](#) for the complete table of external peripheral interrupts.



The no-cost SHIPWare software at [mySerious.com](#) includes a full source-code implementation of a touch driver for the SIM231.



The [Serious Human Interface™ Platform](#) has integrated touch drivers and algorithms that automatically map touch coordinates to GUI objects.

---

## PROXIMITY SENSING

Most standard touch-enabled SIM231 variants include the SX8656 with proximity sensing capabilities which senses the presence of objects (like a bare finger) that alter a projected capacitive field above the touch screen surface. This enables, for example, software to “automatically” brighten the LCD backlight when a finger approaches the screen. Only a general “near” or “not-near” indication is available from this capability, and if the end user is wearing gloves or in a wet environment this feature may not function consistently – an inherent challenge with capacitive detection systems.



The [Serious Human Interface™ Platform](#) has integrated proximity drivers and algorithms that can deliver “near” and “not-near” events to your GUI.

---

## AMBIENT LIGHT SENSING

Some variants of the SIM231 include an Ambient Light Sensor (“ALS”), the [Avago APDS-9002-021](#) or similar device designed to help determine low ambient light situations. Since the backlight on the SIM231’s LCD display can be very bright, especially in these low light situations, software may want to modulate the backlight brightness to improve readability as well as backlight LED longevity. The ALS is connected to MCU analog input **P46/AN006-ALS** and the ambient light intensity can be derived from the ADC value.



The [Serious Human Interface™ Platform](#) has integrated ambient light sensor drivers and algorithms that can deliver a 0 to 100% reading and change-events to your GUI.

**POWER SUPPLIES**

**POWER INPUT: +VIN\_MAIN**

The SIM231 is powered internally from the **+VIN\_MAIN** signal. This signal pulls power from the higher of the two connected inputs **+VEXT** (external voltage) and **+5V\_USB** (USB device input voltage):

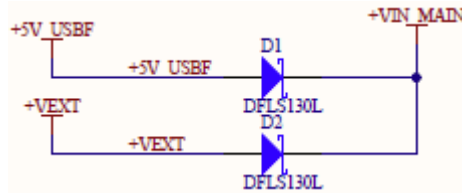

Since the input voltage can have a fairly wide range, as low as 3.6V and as high as 5.5V depending on the variant, there are several switching power supplies attached to **+VIN\_MAIN** to generate voltages required on the SIM231:

Signal Name	Voltage	Circuits Powered
+3V3	3.3 V	▶ MCU, Memory (SDRAM, e-MMC, SD card, Serial FLASH), LCD, Logic, Touch, Temp Sensor
+5V_USBH	5.0 V	▶ USB Host A Connector
PEIZO+/-	<25 Vp-p	▶ Piezo Voltage Booster
BL_LED+/-	~19.2 V	▶ LED Constant Current Backlight

**POWER INPUT: +VEXT**

The main power supply for the SIM231 is generally applied to the **+VEXT** signal available on the following connectors:

Power Signal	Description	Connectors Where Present
+VEXT	External Power	<ul style="list-style-type: none"> <li>▶ <a href="#">16-pin Power/Communications Connector</a></li> <li>▶ <a href="#">60-pin Expansion Connector</a></li> <li>▶ <a href="#">SHIP Programming Port</a></li> </ul>

There is no support for simultaneous power connectivity or dynamic power source switching between these connectors. See the [DC Characteristics](#) for **+VEXT** limits.



**Connecting more than one power source to the SIM +VEXT signals simultaneously may damage your SIM or even connected equipment. Only one connector should drive the +VEXT signal.** The remaining connectors can, within the limits of the SIM, receive power from this signal.

**TURNING SIM231 OFF: PWRDWN#**

All regulators on the SIM231 can be turned off via the **PWRDWN#** signal, available on the following connectors:

- ▶ [16-pin Power/Communications Connector](#)
- ▶ [60-pin Expansion Connector](#)

**PWRDWN#** is weakly pulled high on the SIM to deliver the default powered-on behavior. Driving this signal to **GND** via logic (or connecting it to **GND** via a simple SPST switch) puts the SIM in power down mode. The USB host, and LCD backlight are also powered off, so when **PWRDWN#** is asserted the SIM can consume only a few mA.



**+3.3V (+3V3) REGULATION**

The **+VEXT** main power rail is converted to 3.3 V (the **+3V3** signal) through the ISL9104 or equivalent switching regulator. This regulator is capable of 90%+ efficiency at up to 500mA.

The 3.3V supply (**+3V3**) is used throughout the module, powering most of the logic and peripherals. It is also delivered to the [60-pin Expansion Connector](#) and the [16-pin Power/Communication Connector](#), but is only meant to supply a small amount of power to an attached system. The amount of 3.3V power available to these connectors is limited by (a) the total capacity of the regulator and (b) the excess power available on the **+3V3** signal after calculating the incoming available power minus that used on the SIM231. The [DC Power Characteristics](#) information in this manual can assist in this calculation: the actual amount available is highly dependent on the specific features used on the specific variant selected by the system designer.

**+5V\_USB:USB DEVICE (“FUNCTION”) POWER**

The external USB device supply is merged with the **+VEXT** input via the two forward diodes as described above. The **+5V\_USB** signal is present on the following connectors:

- ▶ [60-pin Expansion Connector](#)
- ▶ [USB Micro B Device Connector](#)
- ▶ [SHIP Programming Port](#)

When driving the **+5V\_USB** input from one of these connectors, it is wise to ensure the **+VEXT** is at or above the nominal 5V of the USB input to ensure the **+VEXT** supply is bearing the primary power needs of the SIM.



The USB Micro B power (**+5V\_USB**) signal on all these connectors is directly connected together: **simultaneous connection may damage the SIM or connected devices such as a PC or USB Hub.**

The SIM231 may be powered from the **+5V\_USB** signal as long as the USB hub or PC port can supply sufficient power to the module, and the features used on the module are used within this power envelope.

**+5V\_USBH: USB HOST POWER**

Some variants include a USB Embedded Host Port with USB A connector. This USB port can supply power to some USB devices, such as keyboards, mice, and thumb drives. A [TI TPS2501 USB Host Power Boost Controller](#) or equivalent ensures that even if **+VEXT** is below 4.75V, the USB Host A connector is still powered with 5.0V as required by the USB standard.

This supply is enabled when the MCU GPIO **P16/USBH\_VBUSEN** is asserted high. **P16/USBH\_VBUSEN** is weakly pulled low so during **RESET#** the USB host power supply is disabled. Similarly, during **PWRDWN#**, this power supply is also disabled.

Up to 150 mA is delivered to the USB Host connector. This 150 mA will be sufficient for all self-powered devices (those devices that have their own, independent power supplies), as well as some bus-powered devices such as USB thumb drives. However, it will not be sufficient for higher bus-powered devices such as USB powered printers and hard drives without their own separate power supplies. The boost controller circuit also provides overcurrent shutoff and controller notification to the **P14/USBH\_OVRCURA** MCU port if the device plugged into the connector draws more than 150mA.



The USB Host power supply and any connected device can be a significant power load on the system. When initially turned on there is an inherent short term power drain as the booster is enabled and the **+5V\_USBH** power is generated and stabilized. If **+VEXT** is too low, the impedance of the external power supply too high, and/or the transient current support of the supply insufficient, then the SIM can reset. Observe the minimum recommended **+VEXT** [DC Maximum Ratings](#) carefully when the USB host feature is used.

LCD PANEL BACKLIGHT POWER: **P11-BLEN** AND **BL\_LED+/BL\_LED-**

The [LCD Panel](#) has an array of LEDs creating the backlight. These LEDs require a constant current source of approximately 25mA, created and managed by an LED driver chip such as the Diodes Inc. AP5724 or On Semi CAT4149 or similar device and delivered to the LCD LEDs on signals **BL\_LED+** and **BL\_LED-**. The voltage on this output can vary, but is typically 19.2V depending on the specific LEDs used in the LCD glass.

The backlight driver is always disabled during **RESET#** and **PWRDWN#**. The backlight driver is enabled when MCU signal **P11-BLEN** is driven high.

Backlight power is a significant portion of the SIM’s power consumption. Software should carefully manage the backlight to be powered on as infrequently and for as short a time as possible – especially in battery powered systems, but also to ensure backlight longevity. Reducing the backlight power can significantly extend backlight lifetimes. Typically, operating the backlight at 50% brightness can more than double the backlight lifetime.

Software algorithms can PWM this pin to enable backlight dimming. A PWM driven by a typical 1 KHz clock with 16 PWM steps for a PWM net frequency of 64 Hz is generally sufficient and flicker free with duty cycles from 0 to 100%. In no circumstances should the PWM clock exceed 16 KHz.



The [proximity](#) and [ambient light](#) sensing features (where available) can be used to assist in extending backlight longevity by dynamically adjusting the backlight power through software.



The display backlight is a significant power load on the system. When turned on there is an inherent short term power surge as well as an overall power demand increase. If **+VEXT** is too low, the impedance of the external power supply too high, and/or the transient current support of the supply insufficient, then the SIM may intermittently reset. Observe the minimum recommended **+VEXT** [DC Maximum Ratings](#) carefully.



The [Serious Human Interface™ Platform](#) has the backlight driver included; setting the platform glass backlight value to 0 to 100% automatically modulates the dimming circuit.

BATTERY BACKED REAL TIME CLOCK/CALENDAR (RTCC): **+VBAT**

Some SIM231 variants have an external I2C-connected battery-backed Real Time Clock/Calendar chip. On these variants, there may also be a coin cell battery holder that, when populated, can keep the clock/calendar running even during **+VEXT** power outages and through **RESET#** and **PWRDWN#** states.



The battery backup is provided from a common CR1025-type 3V battery inserted into a simple battery holder on the SIM. This is not designed to be a rechargeable battery, nor does any circuit on the SIM231 supply power to charge this battery. The only purpose and connection of this coin cell battery is to provide the backup power signal **+VBAT** to the RTCC chip to keep the clock/calendar running in the event that all other power sources are removed. This battery can keep the clock keeping time for up to several years without replacement. The RTCC automatically switches to use the coin cell power only when main power is not available, so in a system that normally has main power applied the coin cell battery is rarely used. See [External RTCC](#) for more information.



**MEMORY**

**SERIAL FLASH**

All SIM231 family members include one or two SST [SST25VF064C](#) serial FLASH devices. The SST25VF064C is an 8 megabyte device with 2048 4KByte erasable blocks as well as a built-in 64-bit unique serial ID and 192 bits of OTP ID space.

See the [SST25VF064C data sheet](#) for hardware specifications and programming details and the Renesas [RX63N/631](#) datasheet for information on the SPI master port configuration.

These devices are connected to RSPCKA SPI channel of the MCU:

Schematic Signal Name	Description	FLASH Name	60-pin Expansion Connector J2 Pin	20-pin PCB Edge Connector J4 Pin
PC6/MOSIA	SPI data MCU→FLASH	SDI	12	4
PC7/MISOA	SPI data FLASH→MCU	SD0	8	6
PC5/RSPCKA	SPI FLASH clock	SCK	15	8

Each of the serial FLASH devices has independent chip selects and reset signals managed by MCU GPIO pins. These signals are also available on some external connectors:

Schematic Signal Name	Description	FLASH Name	60-pin Expansion Connector J2 Pin	20-pin PCB Edge Connector J4 Pin
PC4-SFLASH0_CS#	SPI FLASH0 slave select	CS#	16	12
P23-SFLASH0_RESET#	FLASH0 RESET#	HOLD#/RES#	-	
PC0-SFLASH1_CS#	SPI FLASH1 slave select	CS#	17	
P25-SFLASH1_RESET#	FLASH1 RESET#	HOLD#/RES#	18	

Note these two reset lines are not asserted in module RESET# mode and have weak pull-ups. Both parts have internal power-on-reset circuits and, if desired, software on the MCU can explicitly reset the parts with the P23-SFLASH0\_RESET# and P25-SFLASH1\_RESET# signals. Both FLASH devices can be reprogrammed under software control.

SFLASH0 can be reprogrammed from the [60-pin Expansion Connector](#) and/or [PCB Edge Connector](#) directly using external hardware (for example with the [SHIP Programming Adapter 200 \(SPA200\)](#)) by holding the module in RESET# and exercising the control lines PC4-SFLASH0\_CS#, PC6/MOSIA, PC7/MISOA, and PC5/RSPCKA.

SFLASH1 can be reprogrammed from the [60-pin Expansion Connector](#) directly using external hardware by holding the module in RESET# and exercising the control lines PC0-SFLASH1\_CS#, PC6/MOSIA, PC7/MISOA, and PC5/RSPCKA.

SFLASH1 can be also be “overridden” on a daughter card plugged into the [60-pin Expansion Connector](#). Asserting P25-SFLASH1\_RESET# from a daughter card will render any serial FLASH #1 on the SIM unresponsive to the MCU. Using the PC0-SFLASH1\_CS#, PC6/MOSIA, PC7/MISOA, and PC5/RSPCKA signals to drive an on-daughter-card external serial FLASH device will cause this external FLASH to respond to the MCU as if it were the serial FLASH #1.

Serial FLASH#0 contains factory-programmed information including the [serial number of the unit as well as variant/version information](#).



**Do not write to serial FLASH#0's SST25VF064C's OTP region.**

This region is reserved for manufacturing and configuration information by *Serious*. Modifying or writing to this area will **void your warranty** with *Serious* and render the module unusable.



To use the full features of the [Serious Human Interface™ Platform](#), you need to preserve the *Serious* firmware in the serial FLASH(s). Modifying/erasing either the serial FLASH(s) or RX program FLASH will render the SHIPEngine and boot loader unusable. Restoring these images can be accomplished using [USB Boot mode](#) and SHIPTide/SHIPCrane tools available at [www.seriousintegrated.com](http://www.seriousintegrated.com).

**SDRAM**

The SIM231, depending on the variant, includes an 8 or 16MB SDRAM with a 16-bit data bus configuration. The SDRAM is designed to operate at 48 MHz with a 96MHz MCU core frequency. The MCU's built-in SDRAM controller can be configured to enable this memory in random access or burst modes.



The SHIPWare source code has SDRAM initialization routines you can examine and use with the SIM231. SHIPWare is available at no cost for registered hardware users on mySerious.com.



[SHIPEngine](#) (the runtime engine of the [Serious Human Interface™ Platform](#)) automatically configures and manages the SDRAM



*Serious* makes every attempt to maintain compatibility throughout the availability lifetime of our devices. However components – especially memory – are subject to ongoing and sometimes frequent process, density, and availability changes. SDRAM sizes for each variant are a **minimum specification and vendors may vary. Software must be written to comprehend sizes beyond this minimum specification and various vendors and Serious reserves the right to substitute at any time larger devices than the specified variant minimum.**

**EEPROM**

The SIM231 features an [Atmel ATSHA204](#) Cryptographic/Authentication device. Within this device is 4k bits (512 bytes) of EEPROM for storing security keys and/or parameter data. If the cryptographic and authentication features of the ATSHA204 are not used, the device can be used simply as a user EEPROM.



**Do not write to the ATSHA204's one-time-programmable (OTP) region.**  
The ATSHA204 has 4.5kb total EEPROM, 512 bits of which are an OTP area reserved by *Serious*.  
**Tampering with this OTP area will void your warranty with Serious and render the module unusable.**

The ATSHA204 is an I2C device on the SIM's main I2C control bus. This bus is shared by numerous devices: see the [I2C Device Summary](#) for more information including I2C addresses. Consult the [Atmel ATSHA204 Data Sheet](#) for programming and hardware information of the ATSHA204 device.

**SERIOUS SERIAL NUMBER**

Beyond the 8 or 16MBytes of data area, the SST25VF064C device(s) also contain a 256 bit (32 byte) one-time programmable (OTP) region.

[Serial FLASH #0](#) contains factory-programmed information including the serial number of the unit as well as variant/version information. Reading this information at run-time can enable software to dynamically adapt to the specific variant as well as accommodate any software-visible differences between versions of the specific module.



**Do not write to the SST25VF064C's OTP region.**  
This region is reserved for manufacturing and configuration information by *Serious*.  
Modifying or writing to this area will void your warranty with *Serious* and render the module unusable.



GUIs developed in SHIPTide can display this information at runtime.



The [Serious Human Interface™ Platform](#) PC-based tools, including the [SHIPTide](#) development tool and the SHIPCraner programming tool, can read, display, and decode the [Serious Serial Number](#) for you through the [USB2.0 High-Speed Device Port](#).



Using the *Serious* SHIPBridge protocol, you can fetch the [Serious Serial Number](#) over-the-wire (SPI, UART, USB, etc.) connecting your system of the SIM.

The 32-bit OTP area in the serial FLASH is structured as follows:

Location	Size (Bytes)	Contents	Example
0x00 . . 0x07	8	Unique SST25V064 Serial Number	
0x08 . . 0x09	2	ID	<b>0x0231</b> means SIM231
0x0A	1	<b>Serious Serial Number (SSN)</b> Version (major B7..4 + minor B3..0)	<b>0x21</b> means v2.1
0x0B	1	Variant (see chart below)	<b>0x01</b> means A01
0x0C	1	LCD option (see below)	<b>0x00</b> means R32ALM
0x0D . . 0x0F	3	Sequence number of this unit	<b>0x00023</b>
0x10 . . 0x17	8	Reserved for custom OEM Serial Number	
0x18 . . 0x1F	8	Reserved for <i>Serious</i> manufacturing information	

Locations **0x08...0x0F** form the unique *Serious* Serial Number (SSN) for the module. All values are stored in Big Endian order, regardless of the endian-ness of the processor on the module.

The following table shows Variant and LCD Option maps, correlating the values at locations **0x0B** and **0x0C** respectively to the actual Variants and LCD options on the module:

Variant Byte	SIM535 Variant Name	LCD Option Byte	LCD Option
0x01	-A01	<b>0x00</b>	R32ALM/N32ALM
0x02	-A02		
0x03	-A03		
0x04	-A04		
0xFF	Invalid/Unknown	<b>0xFF</b>	Invalid/Unknown
<b>All others</b>	Reserved	All others	Reserved

### CRYPTOGRAPHIC/AUTHENTICATION DEVICE

The SIM231 features an [Atmel ATSHA204](#) Cryptographic/Authentication device with built-in Random Number Generator (RNG) and EEPROM. The ATSHA204 is an I2C device on the SIM’s main I2C control bus. Within this device is 4kbit (512 byte) EEPROM for storing security keys and/or parameter data. If the cryptographic and authentication features of the ATSHA204 are not used, the device can be used simply as a user EEPROM.



The 512 bit OTP area within the 4.5Kb EEPROM is pre-programmed by *Serious* and is unavailable for other uses. Modifying or writing to this area **will void your warranty with Serious** and render the module unusable.



See the [I2C Device Summary](#) for the complete table of I2C device addresses.



The *Serious* Human Interface™ Platform’s firmware (*SHIPEngine*) uses this device to ensure it is running on authorized *Serious* hardware platforms.

Consult the [Atmel ATSHA204 Data Sheet](#) for programming and hardware information of the ATSHA204 device.

## CLOCKS, OSCILLATORS, AND TIME KEEPING

The following terms are important to understand theory of operation described herein:

- Clock:** A square-wave logic-level periodic signal (not a clock as in a timekeeping clock of time/date/minutes/hours, etc.)
- Oscillator:** A crystal or resonating oscillator circuit that creates a fixed-frequency sine wave used in a specific circuit to create a clock signal
- RTCC:** A real time clock/calendar which keeps track of the correct time/date as set by the end user or some other means.

There are many producers and consumers of stable clock signals (or “clocks”) on the SIM231:

- 1) The RX MCU is typically driven with a 12 MHz clock signal, which is internally in the MCU multiplied by 8 for a 96MHz CPU clock speed.
- 2) Some variants have a 32.768 kHz crystal attached to an external RTCC chip or to the MCU directly.
- 3) The [USB Device port](#) and [USB Host port](#) require a 12MHz clock to operate within USB specifications.

---

### HIGH SPEED (12 MHZ) CLOCK

The SIM231 RX MCU’s high speed clock system is driven by a single 12MHz clock oscillator. In this configuration, the CPU core frequency must be derived from this 12MHz source – typically yielding 96MHz in the x8 PLL mode. USB device and host peripherals are therefore appropriately supplied with 12MHz clocks and the SDRAM bus runs at 48MHz.

---

### MCU REAL-TIME CLOCK/CALENDAR (RTCC)

The RX MCU has an internal Real-Time Clock/Calendar (RTCC) peripheral, designed to be driven from an attached 32.768 KHz crystal or external 32.768 KHz clock source.

Some SIM231 variants have an [external RTCC chip](#). This chip, when properly programmed, delivers a clean 32.768 kHz square wave on its **CLK0** pin to the MCU’s RTCC external clock input **XCIN**. Other variants have a simple 32.768 KHz crystal connected to the RX MCU’s **XCIN/XCOUT** crystal pins. Some variants have no external crystal or clock input for the RTCC. Consult the [variant chart](#) for more information. The RX must be configured (via software and registers) to be enabled and use the correct RTC clock input mode.



The variant can be determined at runtime by reading the [variant information from the serial FLASH](#).

On variants with the [external RTCC chip](#) there may also be a battery backup capability where the clock continues to run and keep time, even when external power is lost or the module is put in **PWRDWN#** or **RESET#** modes.

The MCU’s RTCC, however, is not battery-backed: when system power is lost from the SIM231 (or the [PWRDWN# signal](#) is asserted) the MCU’s RTCC stops operation and timekeeping is lost. The MCU’s RTCC must be re-loaded after every time power is restored to the SIM. In many system architectures, the time/date is available in another portion of the system, and over a communications link the remote time/date can be periodically retrieved and programmed in to the MCU’s RTCC registers.

---

### EXTERNAL RTCC WITH OPTIONAL BATTERY BACKUP

Some SIM231 variants have an external [NXP PCF8523](#) RTCC chip. This RTCC is completely independent of the RX MCU’s RTCC, and some variants support a CR1025 backup lithium coin cell battery such that when main power is lost to the SIM,

the coin cell ensures the external RTCC continues to run and keep time. With a high quality battery, the clock/calendar could run for up to several years without replacement.

The NXP PCF8523 RTCC, if present, has a dedicated 32.768 KHz crystal. The RTCC’s **CLK0** pin is connected to the MCU’s RTCC clock input **XCIN**, and must be configured to output a 32.768 KHz input if the MCU’s RTCC operation is required.

Schematic Signal Name	Description	RTCC Name	MCU Name
CLK_32KHZ	RTCC Clock Output	CLK0	XCIN

The external RTCC is an I2C device on the SIM’s main I2C control bus.



See the [I2C Device Summary](#) for the complete table of I2C device addresses.

Consult [the PCF8523 datasheet](#) for more hardware specifications and programming information.

## AUDIO

Depending on the variant the SIM231 supports various audio options including:

- › piezoelectric sounder for alarm and notification “beeps”
- › the [10-bit Single Channel DAC](#) used as a waveform output



SHIPEngine has built-in audio support. With only a few lines of code you can, for instance, deliver an ADPCM .wav file to the DAC output or make the piezo sounder beep at a given frequency/volume.



Vendors such as [Micrium](#) and [Segger](#) provide software solutions that can deliver audio waveforms to the audio outputs. Renesas also has example code for this feature.

## PIEZO SOUNDER

Some SIM231 variants include a piezoelectric sounder suitable for notifications, alarms, etc.

The sounder is activated by applying a frequency to the **P86-BUZZ** signal. The MCU can hardware-PWM this signal so software will typically be written to drive the sounder at a given frequency with 50% duty cycle for full volume output. The duty cycle can be reduced to lower the volume.

The sounder’s resonant frequency is centered between 2400 and 4000 Hz. Waveforms in this frequency range will generate the loudest perceived sounds.

The voltage multipliers within the Piezo driver are controlled with two MCU GPIO pins, **P05-BZEN1** and **P07-BZEN2** as follows:

P05 - BZEN1	P07 - BZEN2	Voltage Vp-p Max	Volume
0	0	Off	Off
0	1	6.6V	Low
1	0	13.2V	Medium
1	1	19.8V	High

## 10-BIT SINGLE CHANNEL DAC

All SIM231 variants expose the **P03/DAC0** signal from the RX MCU to various connectors. The RX MCU has a built-in 10-bit DAC which can be driven at a software-configured frequency using the MCU's data transfer controller (DTC) or DMA. This 3.3Vp-p output can be used to drive speech-quality audio (via an off-module amplifier/speaker) or used for any other purpose requiring an analog output.



SHIPEngine has built-in audio support using this DAC. With only a few lines of code you can, for instance, deliver an ADPCM .wav file to the DAC output or make the piezo sounder beep at a given frequency/volume.

## USER LED

Some SIM231 variants have a bi-color (red/green) LED located on front of the display-side of the module. A bi-color LED is actually two independent LEDs in one package: the LED on the SIM231 has red and green LEDs that, when both are on, have an amber hue. Typically, a plastic or metal front panel enclosure will expose this LED through a plastic light pipe; for example, the [BiVar PLP1-125-F](#). There is no requirement for an end-system to expose this LED. The enclosure may cover it completely and render it un-viewable if desired.

Schematic Signal Name	Description
P90/LED1_R	LED Right Red
P91/LED1_G	LED Right Green

## I2C DEVICE SUMMARY

Numerous devices on the SIM share the primary I2C bus:

Schematic Signal Name	Description	EEPROM Name
P20/SDA1	I2C Serial Data	SDA
P21/SCL1	I2C Serial Clock	SCL

Each device has a unique I2C address and maximum I2C frequency as follows:

Device	Description	Max kHz	7-Bit Address	Read Byte	Write Byte	Interrupt
SX86XX	Touch Controller	400	1001001	0x93	0x92	P07/IRQ15-TOUCH_IRQ
PCF8523	RTCC	1000	1101000	0xD1	0xD0	
ATSHA204	Security/EEPROM	1000	1100100	0xC9	0xC8	
CAT34C02	Serious daughter cards w/EEPROM	400	1010001	0xA3	0xA2	
Serious	Serious daughter cards w/MCU	400	TBD	TBD	TBD	

## INTERRUPT SUMMARY

The following devices external to the MCU are connected to interrupt inputs on the processor:

Device	Description	Interrupt Purpose	Interrupt
SX8656	<a href="#">Touch Controller</a>	Touch event	IRQ15 on P07
J3.15 J2.42	<a href="#">16-pin Power/Communications Connector</a> <a href="#">60-pin Expansion Connector</a>	Remote SPI interrupt	IRQ13-DS on P45
J3.13 J2.39	<a href="#">16-pin Power/Communications Connector</a> <a href="#">60-pin Expansion Connector</a>	Remote I2C interrupt	IRQ10-DS on P42
U8.B15	<a href="#">Serious Gatling™ Technology</a>		IRQ11-DS on P43

CONNECTORS

SHIP PROGRAMMING PORT

Programming the SIM231’s GUI and SHIPEngine from the SHIPTide development tools is typically accomplished by connecting the PC running SHIPTide to the SIM using the USB Micro B connector on the SIM. The *SHIP Bridge* protocol within the *SHIPEngine* firmware as well as the *Tug Boot Loader* can operate over this USB link.

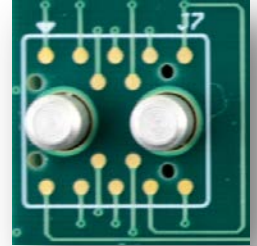

In some variants, the SIM231 will not have the [USB Micro B Device Connector](#) populated and some customer designed enclosures incorporating a SIM system may obstruct access to the [USB Micro B Device Connector](#).

In these cases, the SHIP Programming Port on the SIM231 can be used to expose the USB device port when used with a [SHIP Programming Connector SPC200](#) and [SHIP Programming Adapter 200 \(SPA200\)](#). This port replaces the PCB Edge Connector used on prior SIMs and offers many new features, including:

- › Fast connect/disconnect
- › Robust – up to 1,000,000 insertion cycles for the [SPC200](#) cable-end
- › More features – direct reprogramming capabilities of the Serial FLASH
- › Supports USB 2.0 480mbps High Speed for SIMs with that capability (e.g. SIM535)
- › Small footprint
- › Polarized to prevent connection if the connector is reversed

This new SHIP Programming Port is available and identical on the SIM115, SIM231, and SIM535.

In the case that a daughter card obstructs access to the SHIP Programming Port, this port may be mirrored up on the daughter card – all the signals are available on the [60-pin Expansion Connector](#). Contact *Serious* for details.

SHIP PROGRAMMING CONNECTOR SPC200

Into the SHIP Programming Port is plugged a small connector – the SHIP Programming Connector 200, or SPC200.

This small connector is polarized – plugging it backwards into the SHIP Programming Port does not connect the pins to the SIM.

The SPC delivers the SHIP Programming Port signals to a small cable-friendly connector on one side. It leverages off-the-shelf HDMI cable/connector technology for this purpose, though the signals and power transmitted through the cable *are not compatible with the HDMI standard*.

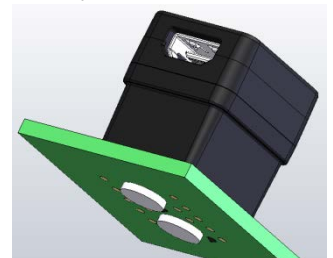

**Do not plug this cable into a normal HDMI port, for example on a laptop, DVD player, or TV.**  
 The connector was chosen to leverage off-the-shelf cabling, but is not wired to the HDMI standard.  
**Connecting the SPC200/SPA200 with to any other device may damage the device or your SIM/SPA permanently.**

Use a short, high quality HDMI v1.4 cable with a “Type D Micro” connector to plug into the SPC200. The other end of the cable should be the larger, more common “Type A” cable which plugs into the SHIP Programming Adapter 200 (SPA200).



SHIP PROGRAMMING ADAPTER 200 (SPA200)

The [Serious Programming Adapter SPA200](#) is an inexpensive programming/USB intelligent adapter for use with the SIM231 and other Serious Integrated Modules. The SPA200 includes the following connectors:

- USB Micro B for a PC to talk to both the SPA and the downstream [USB device port of the SIM](#)
- Barrel Jack for powering the SPA and SIM from a USB AC power adapter
- HDMI Type A connector for connection to the [SPC200](#)'s type D micro-HDMI type D connector via a standard cable

At its very simplest, the SPA200 enables connectivity between a PC USB port and the SIM's USB device circuitry, even if the SIMs USB Micro B connector is not populated or is obstructed. This is necessary for development and volume reprogramming/updating of the GUI and firmware from the SHIP environment.

The SPA200 has numerous other features beyond the scope of this document; contact Serious for more information or visit [www.seriousintegrated.com/SPA200](http://www.seriousintegrated.com/SPA200).

TAG-CONNECT JTAG PORT

[Tag-Connect](#) is a rapid-connection system designed for in-situ reprogramming or connectivity. It adds no cost to the target hardware and is implemented on the PCB through a simple set of landing pads and guide holes. The SIM231 has a 14 pin pad-set designed to accommodate the [TC2070-IDC-NL](#) and associated [TC-FRICTION](#) retaining clip. The port is designed such that the IDC (header) connector on the TC2070 ribbon cable can plug directly into a Renesas E1 or Segger J-Link RX programmer/debugger without any additional adapters or cables.



Plugging into incompatible devices may damage the SIM or connected device.

16-PIN POWER/COMMUNICATIONS CONNECTOR

A common way a SIM231 is connected to another system is via the [JST ZPD Series wire-to-board connector](#). Relevant part numbers are:

JST Part Number	Description
BM16B-ZPDS5-TF(LF)(SN)	Shrouded Header, SMT, 16 position (2x8), Vertical
ZPDR-16V-S	Wire Housing
SZPD-002T-P0.3	Crimp pin for AWG#24 to 28 stranded wire (see  below)

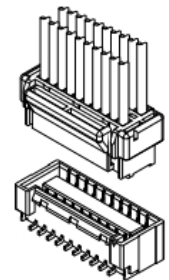

This connector is identical to that found on all upcoming *Serious* modules, including the SIM115, SIM231 and SIM535. Older SIMS had the 7 position JST GH series (SM07B-GHS-TB), and customer feedback indicated that more signals were desired, including **PWRDN#** and the SPI port for higher speed communications. In addition, higher power handling capability was need for larger modules including the SIM535. The JST ZPD series is fully RoHS and UL94V-0 compliant. In addition, it supports full -40 to 85C operation.



While operational to -40C, take care with insertion/removal at low temperature; the housing will be more susceptible to breakage.



The JST ZPD series data sheet indicates a minimum operational temperature of -25C. JST has provided *Serious* a quality and reliability certification for this connector down to -40C. Contact *Serious* for a copy of this certification.



**Ensure sufficient wire size for the SIM to avoid wire overheating and adequate power handling capability.**



Several signals on this connector are directly connected to signals on other connectors, including **+3V3**, **RESET#**, **+VEXT**. **Ensure these connections are appropriate or you may damage your SIM or connected equipment.**





[SHIP Engine](#) v5 can use the UART or SPI on this connector with Modbus or the SHIP Bridge protocol to communicate between the GUI and the attached system.

While the signal wires of the connector can be any size between AWG#24 and AWG#28, the two main power connections (+VEXT, GND) should be sized according to the worst-case power requirements of the SIM, taking into account the anticipated maximum actual operating temperature. AWG#24 stranded high quality wire is recommended for the +VIN and GND power connections, and generally AWG#28 is acceptable for the remaining signals.

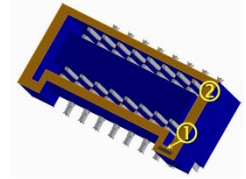

[JST America](#) offers a sample service for wire harnesses, and custom wire harness manufacturers such as [TLC Electronics](#) can assist in small to large volume harness development and production at reasonable cost.

SIM231 development kit versions, such as the SIM231-A01-DEV-01, include a sample single-ended wire harness for your use in prototyping.

Pin	Schematic Net Name	Description
1	+VEXT	Incoming +5VDC power pin; see <a href="#">Power Supplies</a> .
2	GND	System Ground; see <a href="#">Power Supplies</a> .
3	+3V3	Regulated +3.3VDC output from SIM; see <a href="#">Power Supplies</a> .
4	PWRDWN#	Shutdown Input; see <a href="#">Power Supplies</a> .
5	RESET#	System RESET# input and/or output; pulled high on the module.
6	P21/SCL1	I2C Clock (shared with I2C SIM devices)
7	P03/DAC0	GPIO or 3.3V p-p <a href="#">DAC output</a>
8	P20/SDA1	I2C Data (shared with I2C SIM devices)
9	P00/TXD6-XU_TX	With <a href="#">SHIP Engine</a> , this is the primary UART Tx pin (3.3V). Custom software may be able reconfigure this pin in numerous ways
10	P30/MISOB	SPI Master In/Slave Out
11	P01/RXD6-XU_RX	With <a href="#">SHIP Engine</a> , this is the primary UART Rx pin (3.3V). Custom software may be able reconfigure this pin in numerous ways.
12	P26/MOSIB	SPI Master Out/Slave In
13	P42/AN002-XU_TE	With <a href="#">SHIP Engine</a> , this is the UART Tx Enable for half duplex or multi-drop transceivers. When TxEnable is not used, this is commonly used as the I2C IRQ input ( <b>IRQ10-DS</b> ) Custom software may be able reconfigure this pin in numerous ways
14	P27/RSPCKB	SPI Clock
15	P40/AN000/IRQ8DS	May be used as a GPIO, analog input, or interrupt with custom software. With <a href="#">SHIP Engine</a> typically used with the SPI port as an IRQ8.
16	P41/AN001-P31/SSLB0#	SPI Slave Select

There is no legacy full-level RS232 port on the SIM231. However, a simple and very inexpensive adaptor (such as the [CircuitMonkey.com USB-Serial TTL Adapter](#)) can be easily attached to primary 3.3V UART Tx/Rx signals to enable full serial-over-USB communications to a PC. Alternatively, a common RS232 chip (like the venerable [MAX232](#) or similar device) can boost the 3.3V UART levels to traditional RS232 voltages.



Some [Serious Communications Modules \(SCMs\)](#), for example the [Serious Communications Module 117 \(SCM117\)](#) include RS232, RS485, CAN transceivers and more, and dock into the back of the SIM231 directly.

### USB MICRO B DEVICE CONNECTOR

All SIM231 variants have the USB device (or “function” in USB nomenclature) circuitry populated and connected to the MCU’s USB port. However, only some SIM231 variants have the USB Micro B connector present. The electrical signals are always present on the following connectors (when present):

- ▶ [60-pin Expansion Connector](#)
- ▶ [USB Micro B Device Connector](#)
- ▶ [SHIP Programming Port](#)

The USB port is a USB 2.0 Full Speed (12 mbps max) port. The USB Vendor ID (VID) and Product ID (PID) are software dependent. See [www.seriousintegrated.com/docs/usb](http://www.seriousintegrated.com/docs/usb) for information on *Serious* VID/PID combinations.

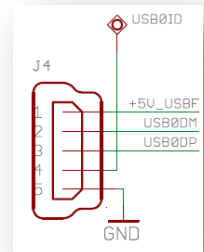



The USB Micro B Power input pin (+5V\_USB) on various other connectors is directly connected to the USB Micro B power input: **connecting any of these simultaneously may damage your SIM or even connected equipment such as a PC or USB Hub.**



[SHIPTide](#) and [SHIPEngine](#) communicate over the USB Device port to download and update the [SHIPEngine](#) and GUI cargo during the development and manufacturing processes.

### USB A HOST CONNECTOR

Some SIM231 variants include USB 2.0 Full Speed embedded host circuitry along with the associated USB “A” Connector. See [USB Embedded Host Port](#) for details on the port functionality and [USB Host Power](#) for power enabling and limitations.

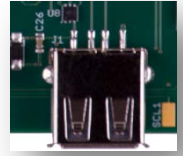

### 60-PIN EXPANSION CONNECTOR

While the [16-pin Power/Communications Connector](#) is a common way to connect an external system to the SIM231, the SIM’s 60-pin Expansion Connector is the most flexible off-module connector available and exposes many more signals. Often a simple 2-layer PCB daughter-card will be attached to the SIM231 using this connector to adapt the SIM231 to a particular system environment.

The 60-pin Expansion Connector (when present) is the [FCI 10106813-061112LF](#), a 60-position, 0.5mm, gold plated, hermaphroditic board-to-board SMT connector. This connector is inexpensive, reliable, and widely carried at authorized distributors, including [Digi-Key](#) and [Arrow Electronics](#).



Ensure you follow the [recommended mechanical guidelines for custom daughter cards](#).

This connector exposes numerous serial, power, and GPIO signals, including the same connections as the [16-pin Power/Communications Connector](#). If desired, this connector can be the only external connection to the SIM231.



[SHIPEngine](#) v5 can use the UART, SPI, or USB signals on this connector as the main communications mechanism for communicating with external systems.



The [RX63N/RX631](#) MCUs have extensive I/O multiplexers allowing one of many different peripheral functions to map to a given I/O pin: consult the [RX63N/RX631 hardware manuals](#) for the complete list of options.



Several signals on this connector are directly connected to signals on other connectors, including **+3V3, RESET#, +VEXT**. **Ensure that common signal connections are appropriate or you may damage your SIM or connected equipment.**

Signals on the SIM 60-pin FCI connector (J2) are as follows:

Signal	Description	Pin
+VEXT	Main input power. See <a href="#">Power Supplies</a> .	1
GND	Ground	2
TRST#	MCU JTAG TRST#	3
RESET#	SIM RESET# input (weakly pulled high on SIM)	4
TCK/FINEC	MCU JTAG TCK or FINEC	5
MD/FINED	MCU Boot Mode or FINED	6
TMS	MCU JTAG TMS	7
PC7/MISOA	SPI MISOA (connected to Serial FLASH, also boot mode select for RX MCU)	8
TDO	MCU JTAG/UART TDO	9
EMLE	MCU JTAG EMLE	10
TDI	MCU JTAG/UART TDI	11
PC6/MOSIA	SPI MOSIA (connected to Serial FLASH)	12
+VEXT	Main input power. See <a href="#">Power Supplies</a> .	13
GND	Ground	14
PC5/RSPCKA	SPI RSPCKA (connected to Serial FLASH)	15
PC4 - SFLASH0_CS#	SPI Slave Select for primary Serial FLASH (weakly pulled high)	16
PC0 - SFLASH1_CS#	SPI Slave Select for secondary Serial FLASH (weakly pulled high)	17
P25 - SFLASH1_RESET#	Secondary Serial FLASH RESET# (weakly pulled high)	18
P47/AN007/IRQ15DS	General purpose I/O	19
P41/AN001 - P31/SSLB0#	General purpose I/O; note this connects 2 RX pins together, do not drive	20
P27/RSPCKB	SPI RSPCK Channel B (no on-SIM devices share this channel)	21
P13/SCA0	I2C Data Channel 0 (no on-SIM devices share this channel)	22
P26/MOSIB	SPI MOSI Channel B (no on-SIM devices share this channel)	23
P12/SCL0	I2C Clock Channel 0 (no on-SIM devices share this channel)	24
P30/MISOB	SPI MISO Channel B (no on-SIM devices share this channel)	25
P03/DAC0	10 bit DAC output 0 to 3.3V	26
+VEXT	Main input power. See <a href="#">Power Supplies</a> .	27
GND	Ground	28
USBF_DP_EX	USB Device Data- (also connected to Micro B if present)	29
P32/CTX0	GPIO P32 or CAN Transmit Channel 0	30
USBF_DM_EX	USB Device Data+ (also connected to Micro B if present)	31
P33/CRX0	GPIO P33 or CAN Receive Channel 0	32
+5V_USBF	<a href="#">USB Device ("Function") Power</a> input to SIM	33
+5V_USBH_EX	<a href="#">USB Host Power</a> output from SIM	34
USBH_DP_EX	USB Host Data+ (also connected to USB A if present)	35
P00/TXD6 - XU_TX	Primary UART Transmit (RX Channel 6)	36
USBH_DM_EX	USB Host Data- (also connected to USB A if present)	37
P01/RXD6 - XU_RX	Primary UART Receive (RX Channel 6)	38
P42/AN002/IRQ10 - XU_TE	Primary UART Transmit Enable (for half duplex etc.)	39
P21/SCL1	I2C Clock Channel 1 (shared with I2C SIM devices)	40
P20/SDA1	I2C Data Channel 1 (shared with I2C SIM devices)	41
P45/AN005/IRQ13DS		42
P41/AN001 - P31/SSLB0#	Connected to both MCU pins; do not drive both simultaneously.	43
+VIN_MAIN	Internal main power; see <a href="#">Power Supplies</a> .	44
+3V3	SIM generated +3.3VDC output; see <a href="#">+3.3V Regulation</a>	45
PWRDWN#	SIM Power Down, weakly pulled high; see <a href="#">Turning SIM231 Off: PWRDWN#</a>	46
+VEXT	Main input power. See <a href="#">Power Supplies</a> .	47
GND	Ground	48
P74/RMII_RXD1	GPIO or Ethernet RMII Receive Data 1 input	49
P75/RMII_RXD0	GPIO or Ethernet RMII Receive Data 0 input	50
P72/ET_MDC	GPIO or Ethernet RMII	51
P83/RMII_CRS_DV	GPIO or Ethernet RMII	52
P77/RMII_RX_ER	GPIO or Ethernet RMII Receive Error input	53
P83/RMII_TXD1	GPIO or Ethernet RMII Transmit 1 output	54
P71/ET_MDIO	GPIO or Ethernet RMII	55
P81/RMII_TXD0	GPIO or Ethernet RMII Transmit 0 output	56
P76/REF50CK	GPIO or Ethernet RMII 50MHz Clock Input	57
P80/RMII_TXD_EN	GPIO or Ethernet RMII Transmit Enable	58
+VEXT	Main input power. See <a href="#">Power Supplies</a> .	59
GND	Ground	60

**From the perspective of a daughter card**, the connector should be wired as follows:

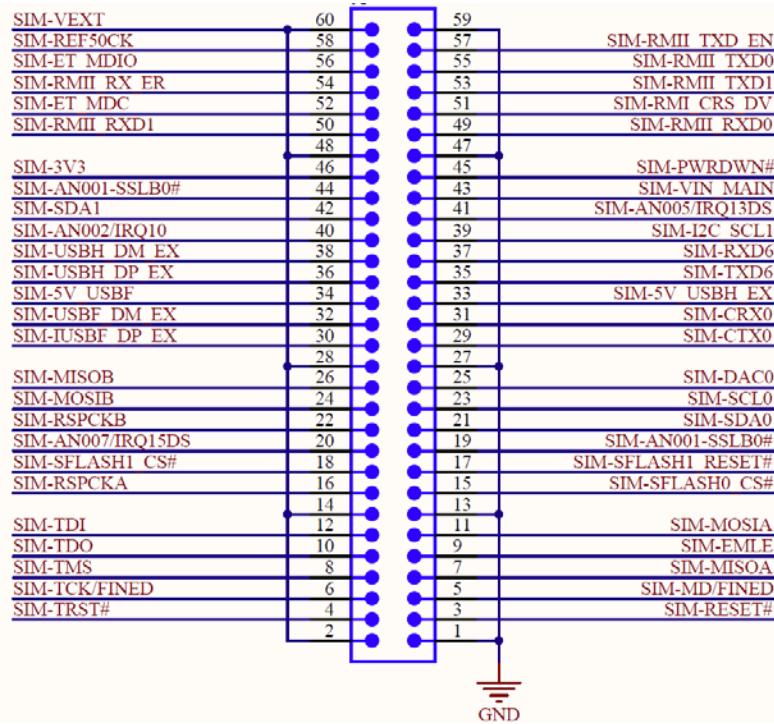

Note the “mirrored” nature of the pin numbering, consistent with [FCI Datasheet practices](#). For example, the above “daughter card perspective” diagram shows pins 1 and 2 as GND and SIM-VEXT respectively, whereas the SIM connection diagram above shows pins 1 and 2 as +VEXT and GND respectively – mirrored.



A complete package, including STEP 3D model as well as an Altium Designer project with board mechanicals, connector positioning, and connector library component are available from *Serious* to help you design your own daughter card. Contact *Serious* for more information.

## UNIVERSIAL SERIAL BUS (USB)

Most SIM231 variants have USB 2.0 Full Speed (12Mbit/s) device (or “function”) capability, though not all variants with the capability also have the associated [USB Micro B Device Connector](#). The USB Device signals may also be available on other connectors on the SIM.

Some SIM231 variants also have a USB 2.0 Full Speed embedded host circuitry and associated “A” connector for support of USB thumb drives, keyboards, mice, etc. The RX MCU USB Host signals, if the circuitry is implemented on the variant, are also available on the [60-pin Expansion Connector](#). This feature enables daughter-cards to expose the USB Host functionality in a physically different location than the SIM, and should only be used to relocate the connector on SIM variants that already have the USB host capability.

## DEVICE IDS

USB devices are uniquely identified by a Vendor ID (“VID”) and Product ID (“PID”). VIDs are assigned under license by the [USB Implementers Forum](#). The *Serious* VID is **0x25D8**.



You may use the *Serious* VID **only with the [Serious Human Interface™ Platform](#) by using [SHIPEngine](#) on the module**. If you wish to program your own software for the SIM, you **must** obtain your own VID from the [USB Implementers Forum](#).



SIM231 comes with the Renesas USB boot mode loader installed, however the USB ID has been modified. The boot loader, when entering [boot loader mode](#), will identify all SIMs (all families) with VID **0x25D8** and PIDs in the **0x0001...0x00FF** range. This boot loader is available for re-installation; see [Additional Information](#).

---

## USB SOFTWARE

Renesas provides extensive documentation of the RX MCU as well as example software: consult the Renesas [USB Driver software website](#).



Vendors such as [Micrium](#) and [Segger](#) provide complete USB stacks pre-ported to [RX63N/631](#) MCUs.

---

## USB2.0 FULL-SPEED DEVICE PORT

The RX MCU used on the SIM has a USB 2.0 Full Speed 12mbps device (or “function”) port. Most variants have the USB device port *circuitry* connected to this port. From a data-connectivity perspective, this port is commonly plugged into a PC and, depending on user-supplied software, can act like any number of PC peripherals such as a serial port.



[SHIPEngine](#) contains built-in USB device stacks and protocols that allow the SIM to communicate directly with [SHIPTide](#) (the rapid GUI development IDE) so GUIs can be downloaded quickly and simply from the PC to the SIM.

While most variants have the USB Device capability, only a subset of these variants has the USB Micro B connector populated. For those with the capability, it is accessible on the following connectors (if present):

- [60-pin Expansion Connector](#)
- [USB Micro B Device Connector](#)
- [SHIP Programming Port](#)

The [SHIP Programming Connector SPC200](#) via the [SHIP Programming Adapter 200 \(SPA200\)](#) can connect into the [SHIP Programming Port](#) on systems where the USB Micro B connector is not populated or is obstructed.

---

## USB2.0 FULL SPEED EMBEDDED HOST PORT

Some SIM231 variants include a USB2.0 Full Speed 12mbps Embedded Host port powered by the RX MCU. This port can (with the appropriate user-supplied software) drive a USB device such as a printer, Wi-Fi module, keyboard, or FLASH thumb drive.

This port can supply up to 150mA of power and has built-in current limiting and over-stress shutdown capabilities. The USB Host power supply system is described [here](#). The USB host power is powered off during system **RESET#** and **PWRDWN#** and must be enabled through software (the **P16/USBH\_VBUSEN** signal on the RX MCU). An overcurrent situation will be indicated on the **P14/USBH\_OVRCURA** signal.

## ADDITIONAL INFORMATION

The home page for SIM231 technical documentation, including schematics, 3D STEP files, and more, is:

[www.seriousintegrated.com/docs/SIM231](http://www.seriousintegrated.com/docs/SIM231)

For technical assistance with the SIM231:

- Contact a [Serious manufacturers' representative](#)
- Contact a [Serious authorized distributor](#)
- Visit [mySerious.com](http://mySerious.com)
- [Contact Serious](#) directly