

LEAD-FREE PLATING

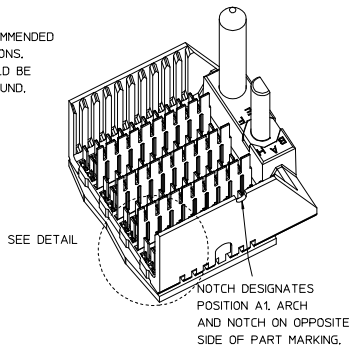
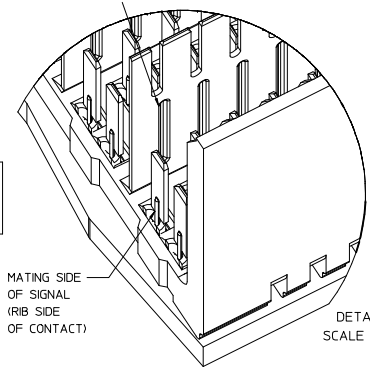

THE PRIMARY CARTON WITH A LABEL STATING "ELV AND RoHS COMPLIANT" IS LEAD-FREE. CARTONS WITHOUT THIS LABEL MAY CONTAIN LEAD.

- NOTES:
1. MATERIAL: HOUSING - LIQUID CRYSTAL POLYMER (LCP) GLASS-FILLED. UL 94V-0. COLOR - GRAY. SIGNAL CONTACT AND GROUND BLADE - HIGH PERFORMANCE COPPER ALLOY.
 2. FINISHES: SELECTIVE GOLD (Au) ON CONTACT AREA, SELECTIVE MATTE TIN (Sn) ON PCB TAILS, NICKEL (Ni) OVERALL.
 3. THIS PART CONFORMS TO MOLEX PRODUCT SPECIFICATION PS-75221-999.
 4. FOR MIXED CONTACT MATING LENGTHS CONSULT MOLEX FOR AVAILABILITY. CONTACT PAIRS MUST BE THE SAME LENGTH.
 5. FOR SPECIFIC PART NUMBER AND MATING INFORMATION PLEASE REFER TO CHART.
 6. PACKAGE PER PK-70873-563.
 7. MARK PART NUMBER AND DATE CODE APPROXIMATELY WHERE SHOWN.
 8. OPTIONAL HOLE LOCATION FOR GROUNDED GUIDE PIN OR ADDITIONAL GUIDE PIN SUPPORT. FOR GROUNDED GUIDE PIN, HOLE TO BE PLATED, DRILL SIZE #258. PAD SIZE #550.
 9. THESE PARTS CONFORM TO MOLEX COSMETIC SPECIFICATION PS-45499-002 CLASS B.
 10. MAPS (MOLEX ADVANCED PLATING SYSTEM).

ASSY PART NO.	K	L	P	TOTAL NO. OF DIFFERENTIAL PAIRS
75235-21**	9	16.65	24.78	40
75235-22**	24	44.40	52.53	100

P/N	75235-()	--x0*	--x1*	--x2*	--x3*	--x4*	--x5*	--x6*	--x7*	--x8*
KEYING PIN ORIENTATION										

PIN LENGTH DIM 'M'	GOLD (Au) THICKNESS micrometers
0-3.55 mm	0.25 (MAPS)
1-4.55 mm	
2-5.55 mm	
3-3.55 mm	0.76
4-4.55 mm	
5-5.55 mm	
7-3.55 mm	1.27
8-4.55 mm	
9-5.55 mm	

REV TO LEADFREE
 EC NO: UCP2013-1905
 DRN: MOLEX 2012/09/07
 CHK: SWANG 2012/09/07
 APPR: MILLER 2012/12/05

QUALITY SYMBOLS	GENERAL TOLERANCES (UNLESS SPECIFIED)	DIMENSION STYLE	SCALE	DESIGN UNITS	THIRD ANGLE PROJECTION
▽=0	4 PLACES ±--- INCH	MM ONLY	5:1	METRIC	
▽=0	3 PLACES ±--- INCH	DRAWN BY: NMARTIN	DATE: 2003/10/22	TITLE: GBX 4-PAIR LF LEFT END BACKPLANE SALES ASSEMBLY	
▽=0	2 PLACES ±0.25 INCH	CHECKED BY: SREED	DATE: 2003/10/22	molex	
▽=0	1 PLACE ±0.38 INCH	APPROVED BY: CBIXLER	DATE: 2003/10/22	DOCUMENT NO. SD-75235-210	
▽=0	0 PLACE ±--- INCH	DRAFT WHERE APPLICABLE MUST REMAIN WITHIN DIMENSIONS		SHEET NO. 1 OF 1	