

Copyright FCI.

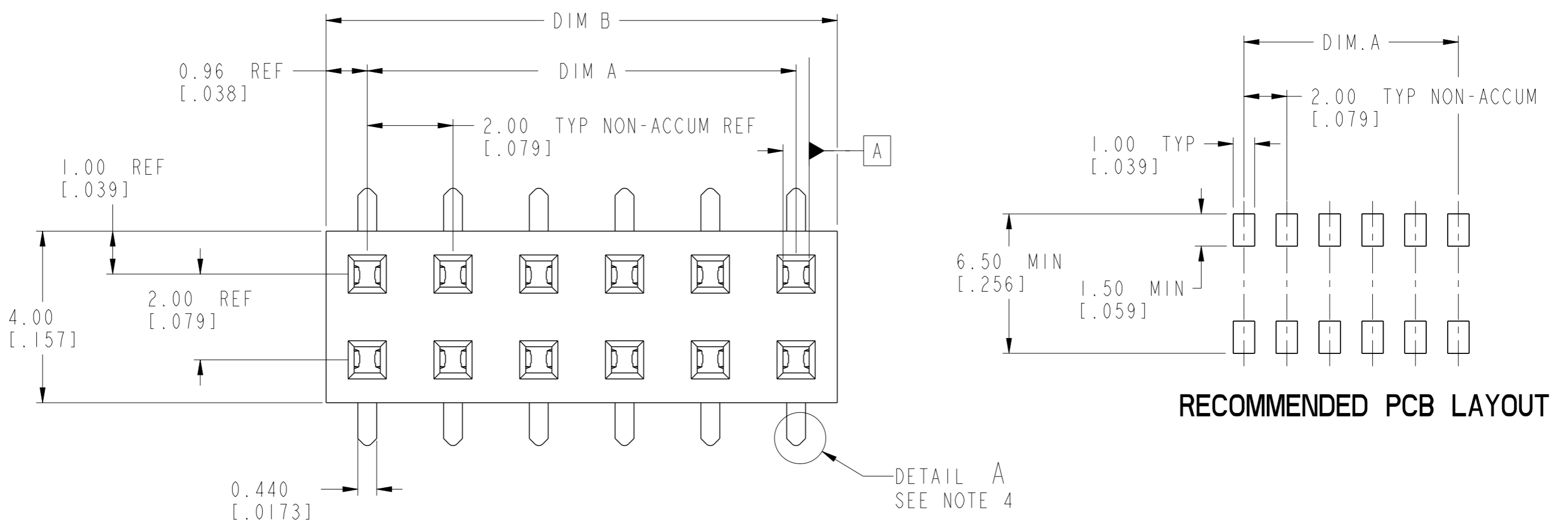

**RECOMMENDED PCB LAYOUT**

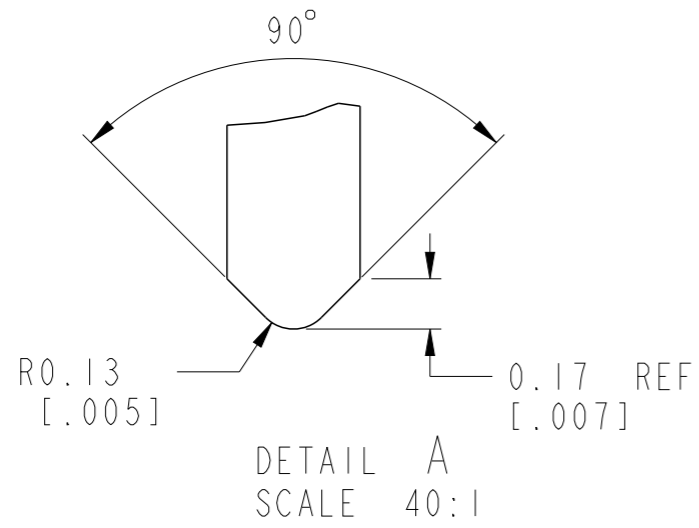
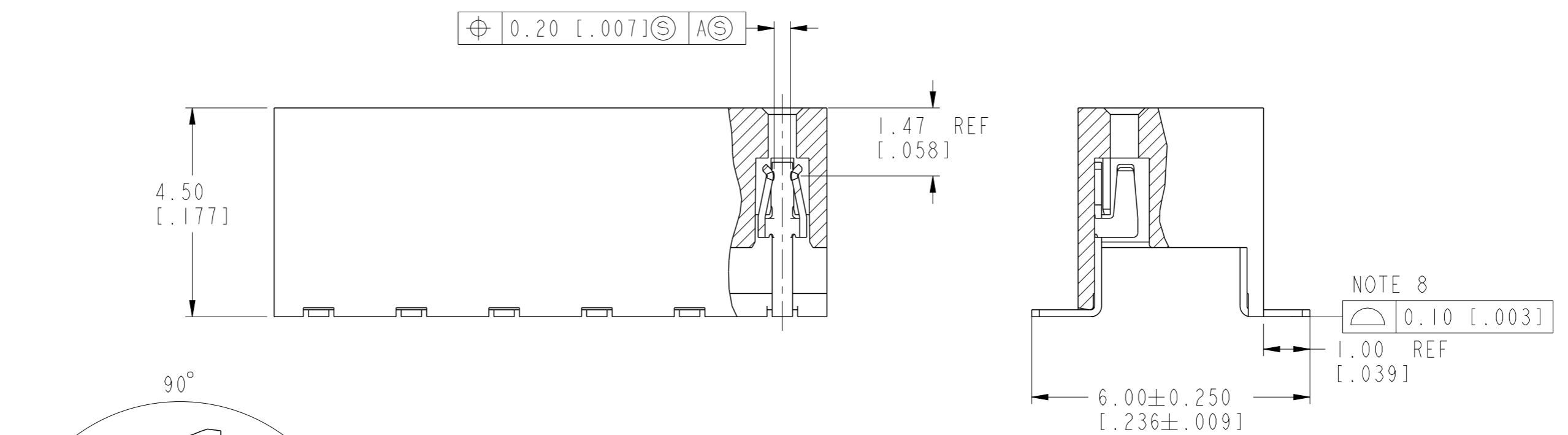

spec ref	-	dr	Andrew Yong	2010/10/14	projection	MM / INCH	size	A3	scale	10:1	
tolerance std	ISO 406 ISO 1101	eng	Su-Hua Miao	2013/01/01			ecn no	ELX-N-13781-1			
TOLERANCES UNLESS OTHERWISE SPECIFIED		chr	-	-			rel level	Released			
surface	ISO 1302	appr	Rick Bian	2013/01/01	product family	LPVCC	dwg no	55510	rev	H	
	linear	0.X	±0.3		cat. no.	-	Product - Customer Drw		sheet 1 of 3		
		0.XX	±0.13		LPVCC						
		0.XXX	±0.051		4.5 TOP ENTRY SMT ASSY						
	angular	0°	±2°	www.fci.com							

PRODUCT NO	PRODUCT NO	POSITIONS	DIM. A	DIM. B
55510-X04 SEE NOTE 5 ▲	55510-X04LF SEE NOTE 6 & 11 ▲	2 X 2	2.00 / .079	3.92 / .154
55510-X06	55510-X06LF	2 X 3	4.00 / .158	5.92 / .233
55510-X08	55510-X08LF	2 X 4	6.00 / .236	7.92 / .312
55510-X10	55510-X10LF	2 X 5	8.00 / .315	9.92 / .391
55510-X12	55510-X12LF	2 X 6	10.00 / .394	11.92 / .469
55510-X14	55510-X14LF	2 X 7	12.00 / .472	13.92 / .548
55510-X16	55510-X16LF	2 X 8	14.00 / .551	15.92 / .627
55510-X18	55510-X18LF	2 X 9	16.00 / .630	17.92 / .706
55510-X20	55510-X20LF	2 X 10	18.00 / .709	19.92 / .784
55510-X22	55510-X22LF	2 X 11	20.00 / .787	21.92 / .863
55510-X24	55510-X24LF	2 X 12	22.00 / .866	23.92 / .942
55510-X26	55510-X26LF	2 X 13	24.00 / .945	25.92 / 1.020
55510-X28	55510-X28LF	2 X 14	26.00 / 1.024	27.92 / 1.099
55510-X30	55510-X30LF	2 X 15	28.00 / 1.102	29.92 / 1.178
55510-X32	55510-X32LF	2 X 16	30.00 / 1.181	31.92 / 1.257
55510-X34	55510-X34LF	2 X 17	32.00 / 1.260	33.92 / 1.335
55510-X36	55510-X36LF	2 X 18	34.00 / 1.339	35.92 / 1.414
55510-X38	55510-X38LF	2 X 19	36.00 / 1.417	37.92 / 1.493
55510-X40	55510-X40LF	2 X 20	38.00 / 1.496	39.92 / 1.572
55510-X42	55510-X42LF	2 X 21	40.00 / 1.575	41.92 / 1.650
55510-X44	55510-X44LF	2 X 22	42.00 / 1.654	43.92 / 1.729
55510-X46	55510-X46LF	2 X 23	44.00 / 1.732	45.92 / 1.808
55510-X48	55510-X48LF	2 X 24	46.00 / 1.811	47.92 / 1.887
55510-X50 SEE NOTE 5 ▼	55510-X50LF SEE NOTE 6 & 11 ▼	2 X 25	48.00 / 1.890	49.92 / 1.965

PLATING OPTIONS OVER CONTACT AREA

- 0 = 0.05um/2u"Au
- 1 = 0.76um/30u"Au
- 3 = 0.38um/15u"Au
- 5 = 2.54um/100u"100% MATTE TIN
- 7 = 0.76um/30u"GXT
- 8 = 0.38um/15u"GXT

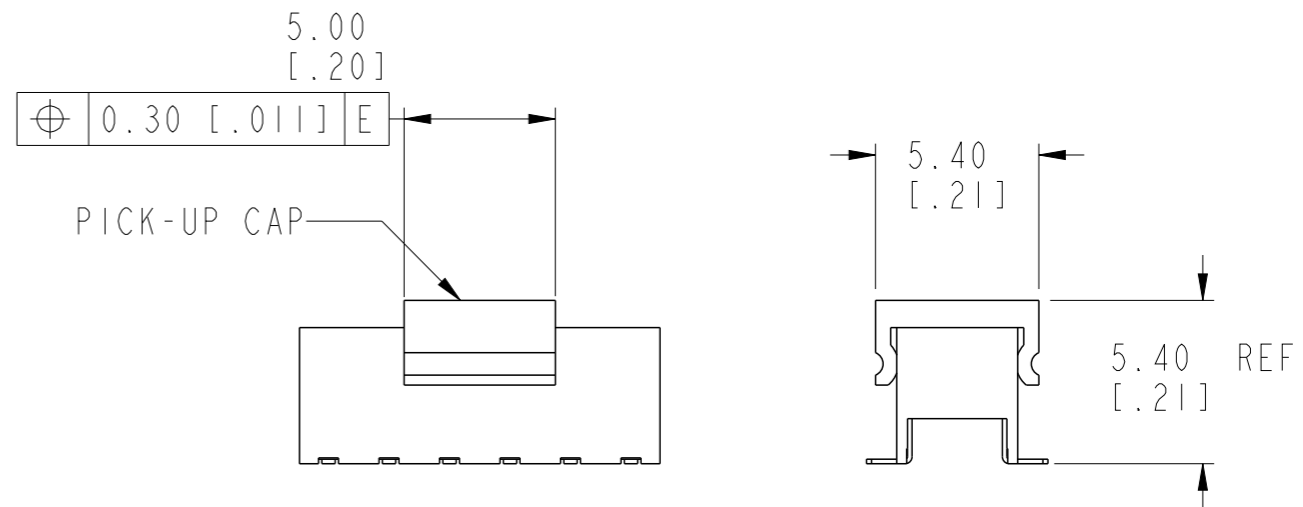

FIG 1  
NOTE 7(b)



Copyright FCI.

dr	Andrew Yong	2010/10/14	projection	MM / INCH	size	A3	scale	10:1
eng	Su-Hua Miao	2013/01/01			ecn no	ELX-N-13781-1		
chr	-	-	product family	LPVCC	rel level	Released		
appr	Rick Bian	2013/01/01						
www.fci.com		cat. no.	-	Product - Customer Drw	sheet 2 of 3			



title LPVCC  
4.5 TOP ENTRY SMT ASSY  
dwg no 55510  
rev H



NOTES:

1. HOUSING MATERIAL : HIGH TEMP PLASTIC.
2. TERMINAL MATERIAL : PHOSPHOR BRONZE.
3. TERMINAL RETENTION 0.5Kg/1.1 Lbs
- ④ 'V' CUT OPTIONAL - MANUFACTURING PROCESS OPTION.
- ⑤ USE TIN/LEAD PLATED SOLDER TAILS.
- ⑥ USE 100% MATTE TIN PLATED SOLDER TAILS
- ⑦ PRODUCT DESCRIPTION CODE:  

XXXXX-X	XXLF	LEAD FREE (SEE NOTE 6 & 11)
		TOTAL POSITIONS
		PLATING AT CONTACT AREA
		BASE NUMBER
- ⑧ PACKAGING:  

(a) XXXXX-XXX	---STD PACKAGING IN TUBE.
(b) XXXXX-XXXTR	---TAPE AND REEL PACKAGING WITH PICK-UP CAP. (FIG 1)
(c) XXXXX-XXXTRN	---TAPE AND REEL PACKAGING WITHOUT PICK-UP CAP.
9. CO-PLANARITY:  

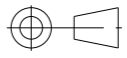
FROM POSITION	- X04 THRU -X38 : 0.10 / .004
	- X40 THRU -X50 : 0.12 / .005
10. PRODUCT SPECIFICATION: GS-12-008
11. THE HOUSING WILL WITHSTAND EXPOSURE TO 255°C PEAK TEMPERATURE FOR 10 SECONDS IN A CONVECTION, INFRA-RED OR VAPOR PHASE REFLOW OVEN.
- ⑫ THIS PRODUCT MEETS EUROPEAN UNION DIRECTIVES AND OTHER COUNTRY REGULATIONS AS DESCRIBED IN GS-22-008.

dr	Andrew Yong	2010/10/14	projection 	MM / INCH ←————→	size	A3	scale	10:1
eng	Su-Hua Miao	2013/01/01			ecn no	ELX-N-13781-1		
chr	-	-	product family		LPVCC	rel level		Released
appr	Rick Bian	2013/01/01			title	LPVCC		rev
					dwg no	55510		H
www.fci.com			cat. no.	-		Product - Customer Drw		sheet 3 of 3

