

THIS DOCUMENT AND THE DATA DISCLOSED HEREIN OR HEREWITH IS NOT TO BE REPRODUCED, USED, OR DISCLOSED IN WHOLE OR IN PART TO ANYONE WITHOUT PERMISSION OF VICOR CORP.

REV.	DESCRIPTION	DATE	APPROVED
1	RELEASED PER E060516	02/21/06	MB
2	REVISED PER E080938	5/6/08	REJH
3	REVISED PER E081632a	08/22/08	CR

WITHOUT SPACER

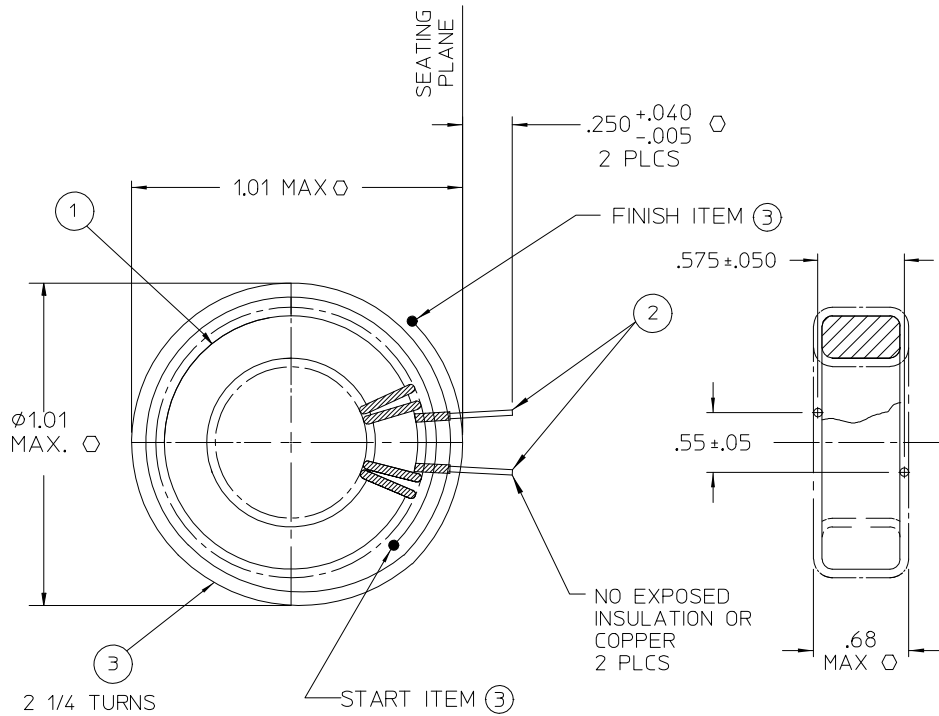

WITH SPACER

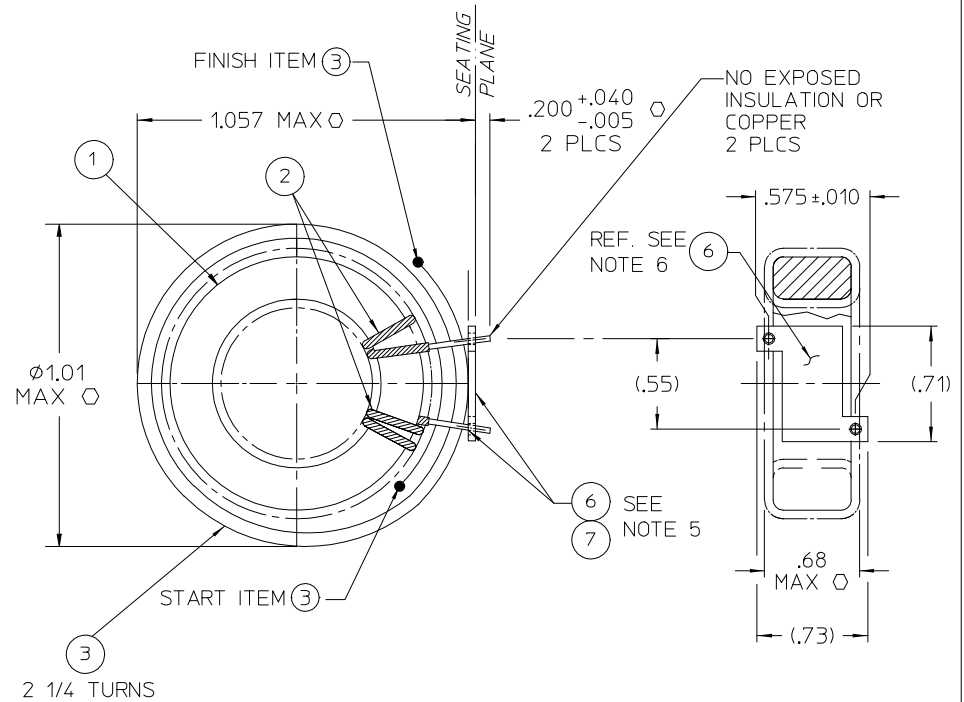

NOTES:

1. ASSEMBLY TO BE FREE OF NICKS.
2. WINDINGS TO BE EVENLY SPACED.
3. RoHS COMPLIANT, LEAD FREE PER CST-0001 LATEST REVISION, MAGNETICS SECTION.
4. GENERAL WORKMANSHIP STANDARDS FOR MAGNETIC COMPONENTS PER WS-0002.
5. BOND SPACER (ITEM 6) TO DEVICE LEADS (2 PLACES), USING ADHESIVE (ITEM 7).
6. ORIENTATION OF ITEM 6 TO BE AS SHOWN.
7. ASSEMBLY MAY NOT HAVE ITEM 3 (TAPE).
8. Ø DENOTES CRITICAL CHARACTERISTIC FOR LOT INSPECTION.

REF VICOR P/N 32011
 REF VICOR P/N 32012
 REF VICOR P/N 32013

DRAWN BY <i>P.E.IENI</i>	DATE 11/14/05				
UNLESS OTHERWISE SPECIFIED DIMENSIONS ARE IN INCHES - TOLERANCES ARE: FRACTIONS DECIMALS ANGLES +1/64 .XX+ .01 *1° .XXX-.005					
THIRD ANGLE PROJECTION		SIZE C	FSCM NO. 67131	DWG NO. 32015	REV 3
DO NOT SCALE DRAWING		SCALE	SHEET 1 OF 1		