

	13	12	11	10	9	8	7	6	5	4	3	2	1
	UNPLATED MATERIAL NUMBER	UNPLATED ENG. NUMBER	PLATED MATERIAL NUMBER	PLATED ENGINEERING NUMBER	STUD SIZE	AWG WIRE RANGE	"S" ±.015/(0.38)	"L" ±.100/(2.54)	"W" ±.035/(0.89)	"C" ±.050/(1.27)	"B" ±.020/(0.51)	"T" ±.020/(0.50)	
J	1922 10423	BCL-1014	1922 10422	BCL-1014-PL	1/4/(6.4)	1/0	.278/(7.06)	1.844/(46.84)	.728/(18.49)	.460/(11.68)	.400/(10.16)	.110/(2.80)	
	1922 10394	BCL-10516	1922 10240	BCL-10516-PL	5/16/(7.9)	1/0	.340/(8.64)	1.844/(46.84)	.728/(18.49)	.460/(11.68)	.400/(10.16)	.110/(2.80)	
	1922 10377	BCL-1038	1922 10241	BCL-1038-PL	3/8/(9.5)	1/0	.400/(10.16)	1.844/(46.84)	.728/(18.49)	.460/(11.68)	.400/(10.16)	.110/(2.80)	
	1922 10441	BCL-1038-WP	1922 10440	BCL-1038-WP-PL	3/8/(9.5)	1/0	.400/(10.16)	1.906/(48.41)	.813/(20.65)	.442/(11.23)	.400/(10.16)	.110/(2.80)	
	1922 10393	BCL-1012	1922 10242	BCL-1012-PL	1/2/(12.7)	1/0	.520/(13.21)	1.844/(46.84)	.728/(18.49)	.460/(11.68)	.400/(10.16)	.110/(2.80)	
	1922 10437	BCL-1012-WP	1922 10436	BCL-1012-WP-PL	1/2/(12.7)	1/0	.520/(13.21)	1.906/(48.41)	.813/(20.65)	.442/(11.23)	.400/(10.16)	.110/(2.80)	
I	1922 10249	BCL-2014	1922 10234	BCL-2014-PL	1/4/(6.4)	2/0	.278/(7.06)	2.062/(52.37)	.824/(20.93)	.522/(13.26)	.461/(11.71)	.110/(2.80)	
	1922 10398	BCL-20516	1922 10243	BCL-20516-PL	5/16/(7.9)	2/0	.340/(8.64)	2.062/(52.37)	.824/(20.93)	.522/(13.26)	.461/(11.71)	.110/(2.80)	
	1922 10379	BCL-2038	1922 10244	BCL-2038-PL	3/8/(9.5)	2/0	.400/(10.16)	2.062/(52.37)	.824/(20.93)	.522/(13.26)	.461/(11.71)	.110/(2.80)	
	1922 10397	BCL-2012	1922 10245	BCL-2012-PL	1/2/(12.7)	2/0	.520/(13.21)	2.062/(52.37)	.824/(20.93)	.522/(13.26)	.461/(11.71)	.110/(2.80)	
	1922 10597	BCL-2058	1922 10598	BCL-2058-PL	5/8/(15.9)	2/0	.656/(16.66)	2.062/(52.37)	.824/(20.93)	.522/(13.26)	.461/(11.71)	.110/(2.80)	
	1922 10478	BCL-3014	1922 10570	BCL-3014-PL	1/4/(6.4)	3/0	.278/(7.06)	2.156/(54.76)	.916/(23.27)	.501/(12.73)	.511/(12.93)	.115/(2.92)	
	1922 10402	BCL-30516	1922 10246	BCL-30516-PL	5/16/(7.9)	3/0	.340/(8.64)	2.156/(54.76)	.916/(23.27)	.501/(12.73)	.511/(12.93)	.115/(2.92)	
H	1922 10381	BCL-3038	1922 10247	BCL-3038-PL	3/8/(9.5)	3/0	.400/(10.16)	2.156/(54.76)	.916/(23.27)	.501/(12.73)	.511/(12.93)	.115/(2.92)	
	1922 10401	BCL-3012	1922 10248	BCL-3012-PL	1/2/(12.7)	3/0	.520/(13.21)	2.156/(54.76)	.916/(23.27)	.501/(12.73)	.511/(12.93)	.115/(2.92)	
	1922 10502	BCL-40516(.625)	1922 10503	BCL-40516-PL(.625)	5/16/(7.9)	4/0	.340/(8.63)	2.688/(68.28)	1.099/(27.91)	.557/(14.15)	.625/(15.88)	.135/(3.43)	
	1922 10374	BCL-4038(.625)	1922 10371	BCL-4038-PL(.625)	3/8/(9.5)	4/0	.400/(10.16)	2.688/(68.28)	1.099/(27.91)	.557/(14.15)	.625/(15.88)	.135/(3.43)	
	1922 10375	BCL-4012(.625)	1922 10372	BCL-4012-PL(.625)	1/2(12.7)	4/0	.520/(13.21)	2.688/(68.28)	1.099/(27.91)	.557/(14.15)	.625/(15.88)	.135/(3.43)	
	1922 10376	BCL-4058(.625)	1922 10373	BCL-4058-PL(.625)	5/8 (15.9)	4/0	.656/(16.66)	2.688/(68.28)	1.099/(27.91)	.557/(14.15)	.625/(15.88)	.135/(3.43)	
G	1922 10413	BCL-40516	1922 10412	BCL-40516-PL	5/16/(7.9)	4/0	.340/(8.63)	2.344/(59.54)	.999/(25.37)	.550/(13.97)	.559/(14.20)	.135/(3.43)	
	1922 10382	BCL-4038	1922 10250	BCL-4038-PL	3/8/(9.5)	4/0	.400/(10.16)	2.344/(59.54)	.999/(25.37)	.550/(13.97)	.559/(14.20)	.135/(3.43)	
	1922 10403	BCL-4012	1922 10251	BCL-4012-PL	1/2(12.7)	4/0	.520/(13.21)	2.344/(59.54)	.999/(25.37)	.550/(13.97)	.559/(14.20)	.135/(3.43)	
	1922 10446	BCL-25038	1922 10447	BCL-25038-PL	3/8/(9.5)	250	.400/(10.16)	2.656/(67.46)	1.203/(30.56)	.676/(17.17)	.685/(17.40)	.125/(3.18)	
	192210652	BCL-4014	192210648	BCL-4014-PL	1/4/(6.4)	4/0	.278/(7.061)	2.344/(59.54)	.984/(24.99)	.550/(13.97)	.559/(13.97)	.135/(3.43)	
	-	-	192210847	BCL-1010MM-PL	10mm	1/0	.417/(10.59)	1.844/(46.84)	.728/(18.49)	.460/(11.86)	.400/(10.16)	.110/(2.80)	
	-	-	192210848	BCL-2010MM-PL	10mm	2/0	.417/(10.59)	2.062/(52.37)	.824/(20.93)	.522/(13.26)	.461/(11.71)	.110/(2.80)	
F	-	-	192210862	BCL-3010MM-PL	10mm	3/0	.417/(10.59)	2.156/(54.76)	.916/(23.273)	.501/(12.73)	.511/(12.93)	.115/(2.92)	

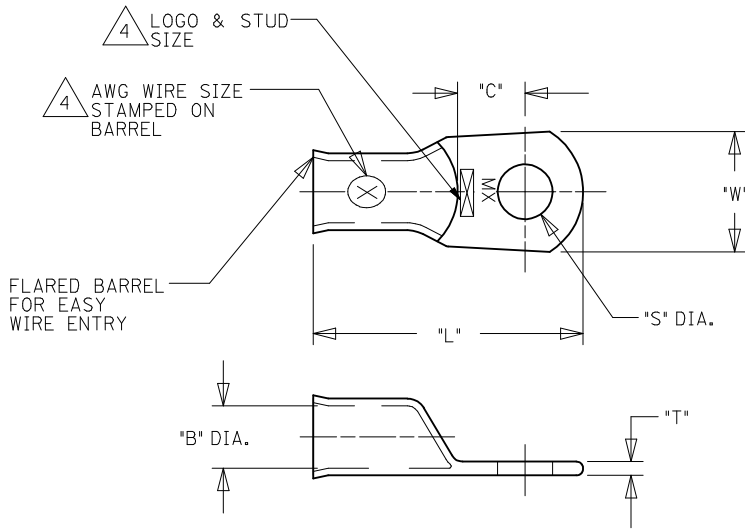

SALES DRAWING

NOTES:

- FOR INSPECTION SIGHT HOLE, PLEASE CONSULT FACTORY.
- OTHER STUD SIZES MAY BE AVAILABLE, PLEASE CONSULT FACTORY.
- MATERIAL: COPPER  
PLATING: TIN
- MARKINGS CAN BE AT EITHER LOCATION SHOWN.
- IF TONGUE IS TO BE BENT AT ANY ANGLE, IT MUST BE BENT AROUND A RADIUS ONE HALF THE TONGUE THICKNESS.
- USE .625/(15.88) BARREL I.D. FOR HIGH STRAND WELDING CABLE.

ADD MATL #. BCL-4058(.625) EC NO: IPGZ2016-0026 DRWINGRO JASO1 2015/07/06 CHKD: JACNEIL 2015/07/06 APPR: JACNEIL 2015/07/13 (REV) DESCRIPTION	QUALITY SYMBOLS	GENERAL TOLERANCES (UNLESS SPECIFIED) <table border="1"> <tr><th colspan="2">mm</th><th colspan="2">INCH</th></tr> <tr><td>4 PLACES</td><td>± .005</td><td>± .005</td><td>± .005</td></tr> <tr><td>3 PLACES</td><td>± .005</td><td>± .005</td><td>± .005</td></tr> <tr><td>2 PLACES</td><td>± 0.13</td><td>± .01</td><td>± .01</td></tr> <tr><td>1 PLACE</td><td>± 0.25</td><td>± .02</td><td>± .02</td></tr> <tr><td colspan="2">ANGULAR</td><td>± ---°</td><td>± ---°</td></tr> </table>	mm		INCH		4 PLACES	± .005	± .005	± .005	3 PLACES	± .005	± .005	± .005	2 PLACES	± 0.13	± .01	± .01	1 PLACE	± 0.25	± .02	± .02	ANGULAR		± ---°	± ---°	DIMENSION STYLE	SCALE	DESIGN UNITS	THIRD ANGLE PROJECTION
	mm		INCH																											
	4 PLACES		± .005	± .005	± .005																									
	3 PLACES		± .005	± .005	± .005																									
2 PLACES	± 0.13	± .01	± .01																											
1 PLACE	± 0.25	± .02	± .02																											
ANGULAR		± ---°	± ---°																											
	IN/MM	--	INCH																											
	DRAWN BY DATE	TITLE																												
	BRE 2002/06/24	BATTERY CABLE LUG COPPER TERMINALS 1/0, 2/0, 3/0 & 4/0																												
	CHECKED BY DATE	MATERIAL NO.																												
	HEB 2002/06/24	SEE CHART																												
	APPROVED BY DATE	DOCUMENT NO.																												
	RWD 2002/06/24	SD-19221-011																												
		SHEET NO.																												
		1 OF 1																												

DRAFT WHERE APPLICABLE MUST REMAIN WITHIN DIMENSIONS

THIS DRAWING CONTAINS INFORMATION THAT IS PROPRIETARY TO MOLEX INCORPORATED AND SHOULD NOT BE USED WITHOUT WRITTEN PERMISSION