

# Surface Mount PTC

## OZCK Series

**HF** **Pb** OZCK Series -0805 Chip

RoHS 6 Compliant & Halogen-Free

### Application

All high-density boards

### Product Features

0805 Chip Size , Fast Trip Time, Low DCR Resistance

### Operating (Hold Current) Range

100mA - 1A

### Maximum Voltage

6 - 15V (per table)

### Temperature Range

-40°C to 85°C

### Agency Approval

TUV (Std. EN60738-1-1, Cert. R50102117)

UL Component (Std. UL1434, File E305051)

UL Conditions of Acceptability:

1. These devices have been investigated for use in safety circuits and are suitable as a limiting device.
2. These devices have been calibrated to limit the current to 8 amps within 5 seconds, per ANSI/NFPA 70, "National Electrical Code".

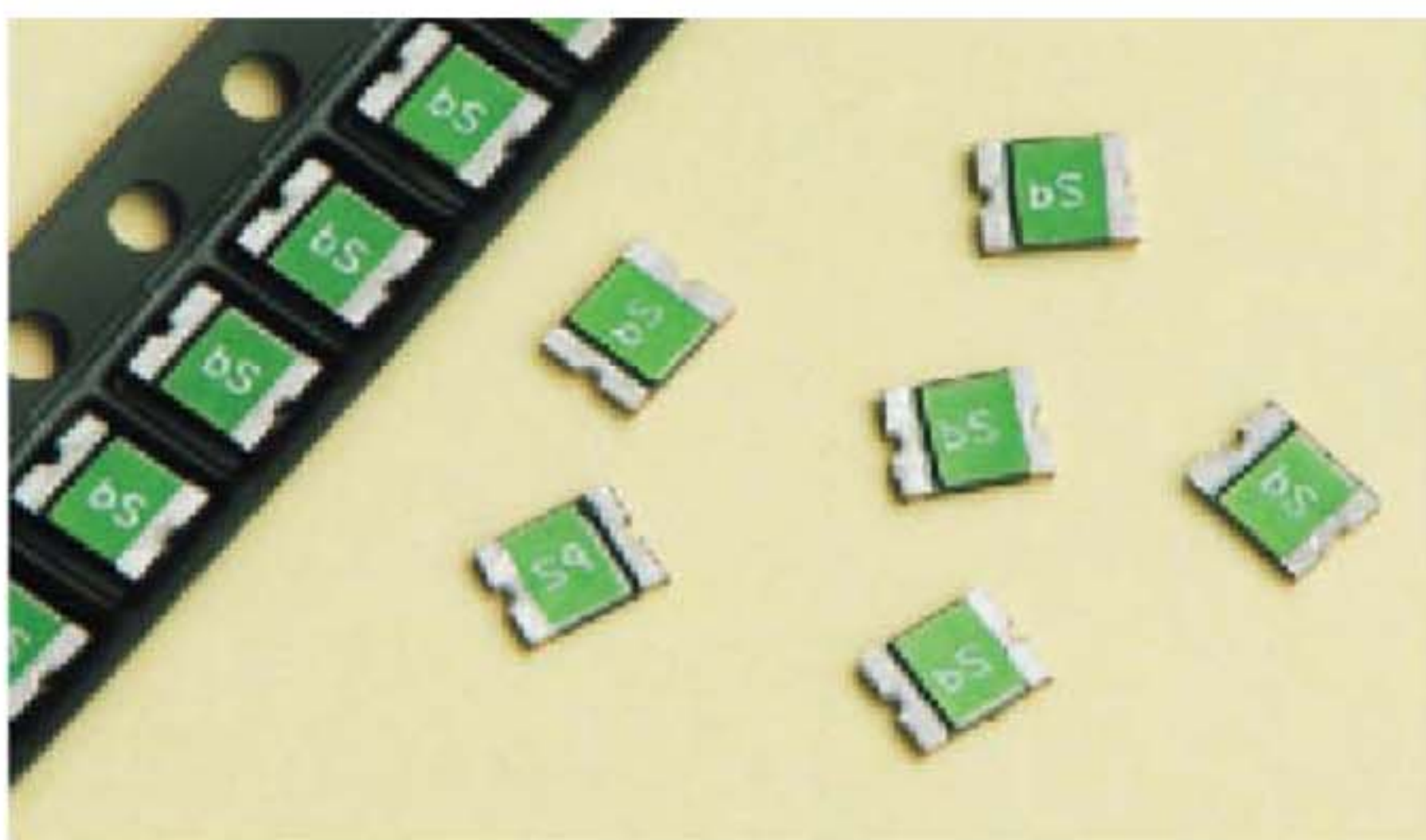

LEAD FREE = **Pb**

HALOGEN FREE = **HF**

### Electrical Characteristics (23°C)

|   | Part Number  | Hold Current | Trip Current | Rated Voltage | Maximum Current      | Typical Power | Max Time to Trip |      | Resistance Tolerance |       | Agency Approvals |            |
|---|--------------|--------------|--------------|---------------|----------------------|---------------|------------------|------|----------------------|-------|------------------|------------|
|   |              |              |              |               |                      |               | Current          | Time | Rmin                 | R1max | <b>UL</b>        | <b>TUV</b> |
|   |              | IH, A        | IT, A        | Vmax, Vdc     | I <sub>max</sub> , A | Pd, W         | A                | Sec  | Ohms                 | Ohms  |                  |            |
| A | OZCK0010FF2G | 0.10         | 0.30         | 15            | 100                  | 0.5           | 0.50             | 1.50 | 0.700                | 6.000 | Y                | Y          |
| B | OZCK0020FF2G | 0.20         | 0.50         | 9             | 100                  | 0.5           | 8.00             | 0.02 | 0.400                | 3.500 | Y                | Y          |
| C | OZCK0035FF2G | 0.35         | 0.75         | 6             | 100                  | 0.5           | 8.00             | 0.10 | 0.250                | 1.200 | Y                | Y          |
| D | OZCK0050FF2E | 0.50         | 1.00         | 6             | 100                  | 0.5           | 8.00             | 0.10 | 0.150                | 0.850 | Y                | Y          |
| E | OZCK0075FF2E | 0.75         | 1.50         | 6             | 40                   | 0.6           | 8.00             | 0.20 | 0.090                | 0.350 | Y                | Y          |
| F | OZCK0100FF2E | 1.00         | 1.95         | 6             | 40                   | 0.6           | 8.00             | 0.30 | 0.060                | 0.210 | Y                | Y          |

- IH Hold Current-maximum current at which the device will not trip in still air at 23°C.
- IT Trip current-minimum current at which the device will always trip in still air at 23°C.
- I<sub>max</sub> Maximum fault current device can withstand without damage at rated voltage (V<sub>max</sub>).
- V<sub>max</sub> Maximum voltage device can withstand without damage at its rated current.
- Pd Typical power dissipated by device when in tripped state in 23°C still air environment.
- Rmin Minimum device resistance at 23°C.
- R1max Maximum device resistance at 23°C, 1 hour after initial device trip, or after being soldered to PCB in end application.

Specifications subject to change without notice



Bel Fuse Inc.  
206 Van Vorst Street  
Jersey City, NJ 07302 USA

+1 201.432.0463  
techhelp@belf.com  
[belfuse.com](http://belfuse.com)

# Surface Mount PTC

## OZCK Series

HF Pb OZCK Series -0805 Chip

RoHS 6 Compliant & Halogen-Free

### PTC's - Basic Theory of Operation / "Tripped" Resistance Explanation

Fundamentally, a Bel PTC consists of a block of polymeric material containing conductive filler and bonded between two conductive, planar terminations.

At currents below the device I<sub>HOLD</sub> rating, AND at temperatures below 100C, the PTC maintains a resistance value below its R<sub>1 MAX</sub> rating.

As the device's temperature approaches 130C, either due to an increase in ambient temperature or a current exceeding its I<sub>TRIP</sub> rating, volumetric expansion of the filled polymer breaks apart the majority of conductive pathways across the terminals created by chain contact of adjacent filler particles or device resistance increases sharply by several orders of magnitude.

At the much higher "Tripped" resistance, there is just enough leakage current to allow internal heating to "hold" the device in its tripped state (around 125C) until power is interrupted. Once power is removed, the PTC's core cools and contracts allowing conductive chains to reform and return the device to its low resistance state.

The catalog data for each device specifies a "Typical Power" value. This is the power required to exactly match the heat lost by the tripped device to its ambient surroundings at 23C. By Ohm's Law, power can be stated as:  $W = E^2/R$ . Thus the approximate resistance of a "Tripped" PTC can be determined by:  $R = E^2/W$ , where "E" is the voltage appearing across the PTC (usually the supply's open circuit voltage), and "W" is the Typical Power value for the particular PTC. Since the PPTC acts to maintain a constant internal temperature, its apparent resistance will change based upon applied voltage and, to a lesser degree, ambient conditions. Consider the following example....

A PTC with a Typical Power of 1 watt protecting a circuit using a 60V supply will demonstrate an apparent, tripped resistance "R" of:

$$R = 60^2/1 = 3,600 \text{ ohms}$$

This same tripped device when used to protect a 12V circuit would now present an apparent resistance of:

$$R = 12^2/1 = 144 \text{ ohms}$$

The value for Typical Power is "typical" because any physical factors that affect heat loss (such as ambient temperature or air convection) will somewhat alter the level of power that the PTC needs to maintain its internal temperature. In short, PTCs do not exhibit a constant, quantifiable tripped resistance value.

### Type Time - To - Trip at 23°C

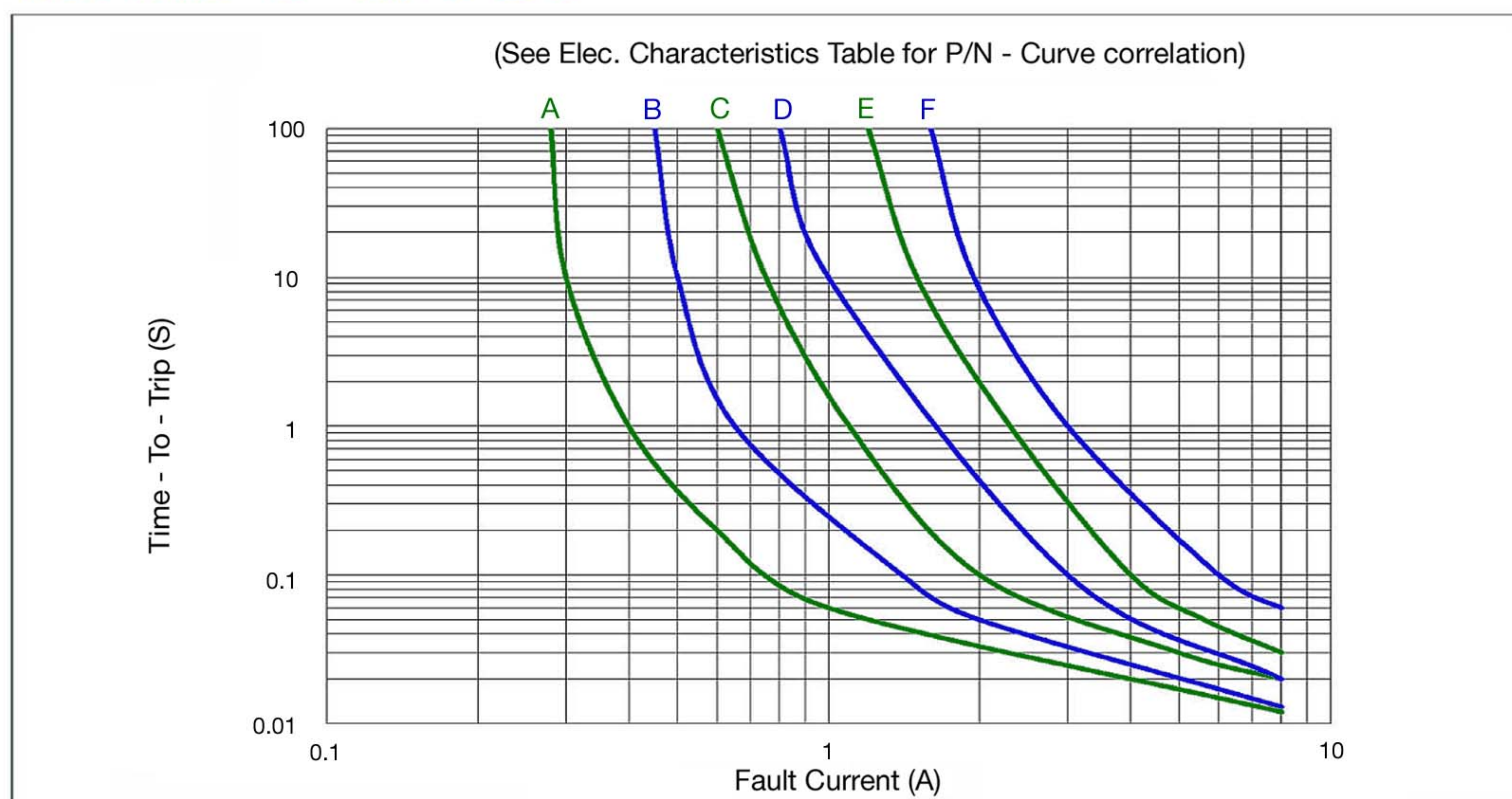

Specifications subject to change without notice



Bel Fuse Inc.  
206 Van Vorst Street  
Jersey City, NJ 07302 USA

+1 201.432.0463  
techhelp@belf.com  
[belfuse.com](http://belfuse.com)

# Surface Mount PTC

## OZCK Series

HF  OZCK Series -0805 Chip

RoHS 6 Compliant & Halogen-Free

### Pad Layout

The dimensions in the table below provide the recommended pad layout.

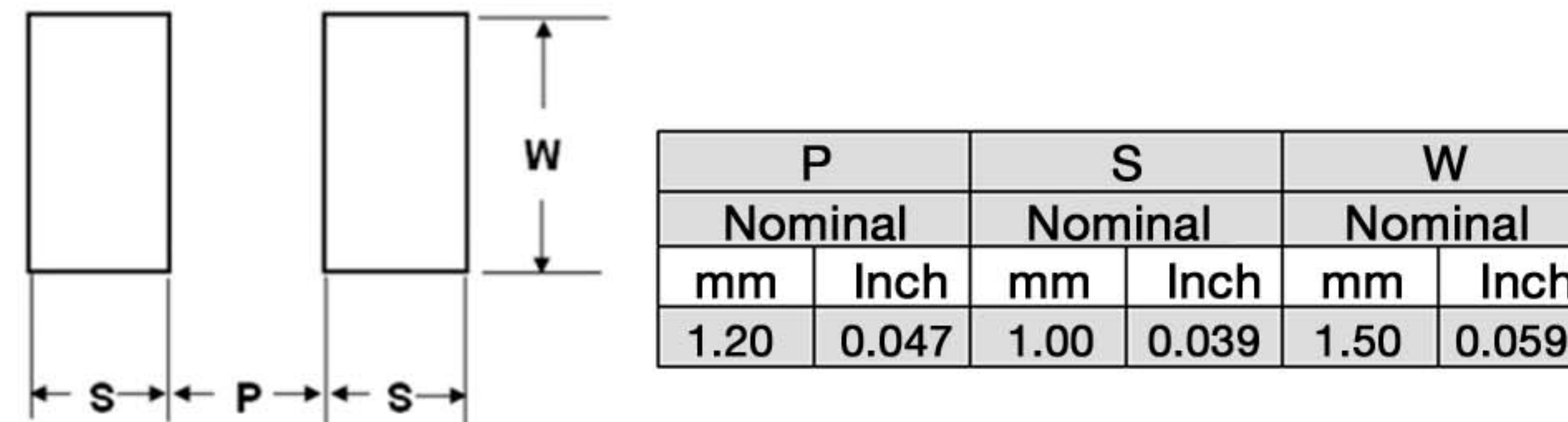

### PTC Marking

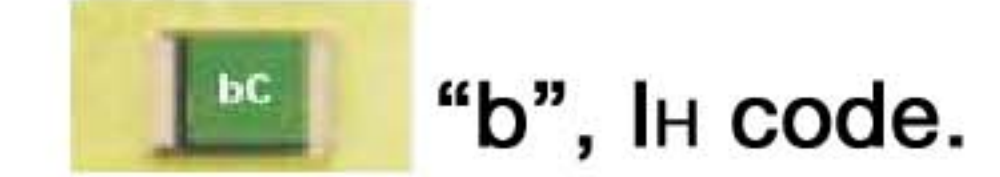

| Part Number  | IH Code |
|--------------|---------|
| OZCK0010FF2G | D       |
| OZCK0020FF2G | F       |
| OZCK0035FF2G | J       |
| OZCK0050FF2E | M       |
| OZCK0075FF2E | P       |
| OZCK0100FF2E | 1       |

### Termination Pad Materials

Matte Tin - Plated Copper

### Mechanical Dimensions

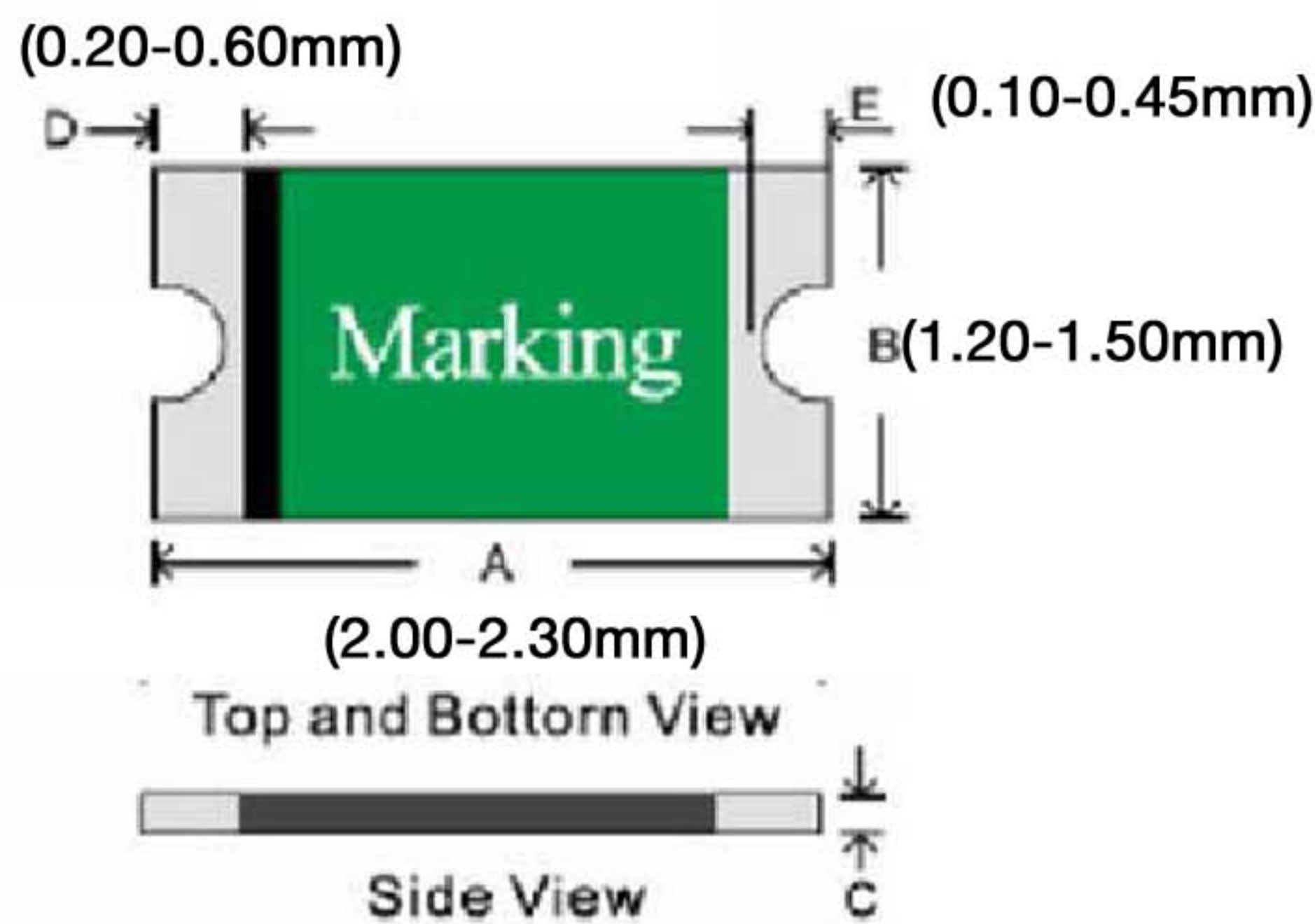

All dimensions in mm.

| Part Number  | C    |      |
|--------------|------|------|
|              | Min  | Max  |
| OZCK0010FF2G | 0.30 | 1.00 |
| OZCK0020FF2G | 0.30 | 1.00 |
| OZCK0035FF2G | 0.25 | 0.75 |
| OZCK0050FF2E | 0.55 | 1.25 |
| OZCK0075FF2E | 0.55 | 1.25 |
| OZCK0100FF2E | 0.75 | 1.80 |

### Thermal Derating Curve

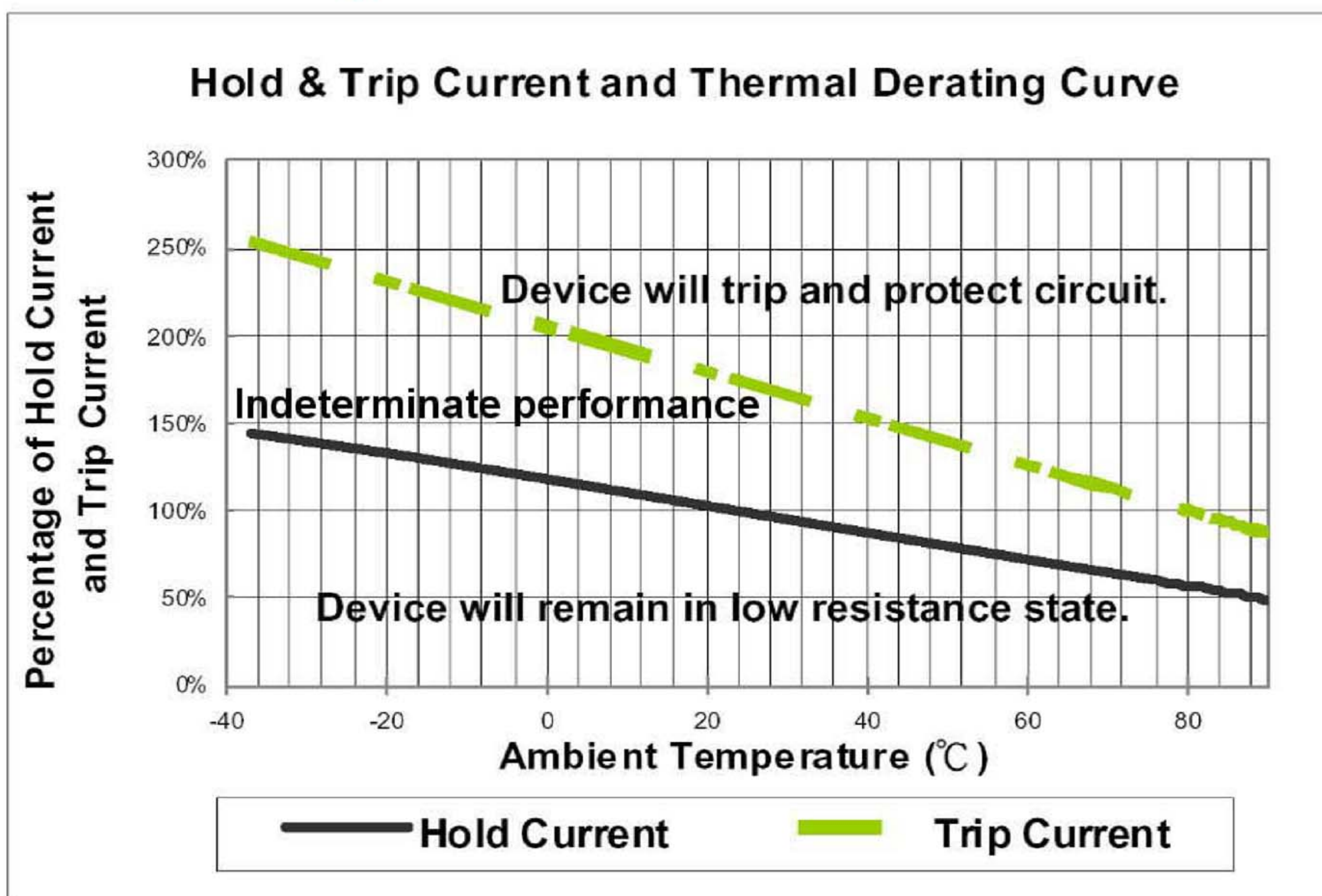

### Cautionary Notes

1. Operation beyond the specified maximum ratings or improper use may result in damage and possible electrical arcing and/or flame.
2. These Polymer PTC (PPTC) devices are intended for protection against occasional overcurrent/ overtemperature fault conditions and may not be suitable for use in applications where repeated and/or prolonged fault conditions are anticipated.
3. Avoid contact of PTC device with chemical solvent. Prolonged contact may adversely impact the PTC performance.
4. These PTC devices may not be suitable for use in circuits with a large inductance, as the PTC trip can generate circuit voltage spikes above the PTC rated voltage.
5. These devices are intended for use in DC voltage applications only. Use in AC voltage applications should be first discussed with Bel Fuse engineering.
6. Not recommended for use on potted or conformal coated PCB's. Restriction of free air flow could affect electrical performance and/or result in device failure. Consult Bel Fuse engineering.
7. In the "Indeterminate Performance / grey zone", tripping may occur but cannot be relied upon. For special circumstances considering use within this region, consult Bel Fuse Engineering.
8. MSL : 2a (According to IPC J-Std-020).

Specifications subject to change without notice



Bel Fuse Inc.  
206 Van Vorst Street  
Jersey City, NJ 07302 USA

+1 201.432.0463  
techhelp@belf.com  
[belfuse.com](http://belfuse.com)

# Surface Mount PTC

## OZCK Series

HF  OZCK Series -0805 Chip

RoHS 6 Compliant & Halogen-Free

### Solder Reflow and Rework Recommendations

| Profile Feature   | Pb-Free Assembly |
|---|------------------|
| Average Ramp-Up Rate (T <sub>smax</sub> to T <sub>p</sub> ) | 3°C/second max   |
| Preheat :   |                  |
| Temperature Min (T <sub>smin</sub> )                        | 150°C            |
| Temperature Max (T <sub>smax</sub> )                        | 200°C            |
| Time (t <sub>smin</sub> to t <sub>smax</sub> )              | 60-180 seconds   |
| Time maintained above:                                      |                  |
| Temperature(T <sub>L</sub> )                                | 217°C            |
| Time (t <sub>L</sub> )                                      | 60-150 seconds   |
| Peak/Classification Temperature(T <sub>p</sub> ) :          | 260°C            |
| Time within 5°C of actual Peak :                            |                  |
| Temperature (t <sub>p</sub> )                               | 20-40 seconds    |
| Ramp-Down Rate :  | 6°C/second max.  |
| Time 25°C to Peak Temperature :                             | 8 minutes max    |

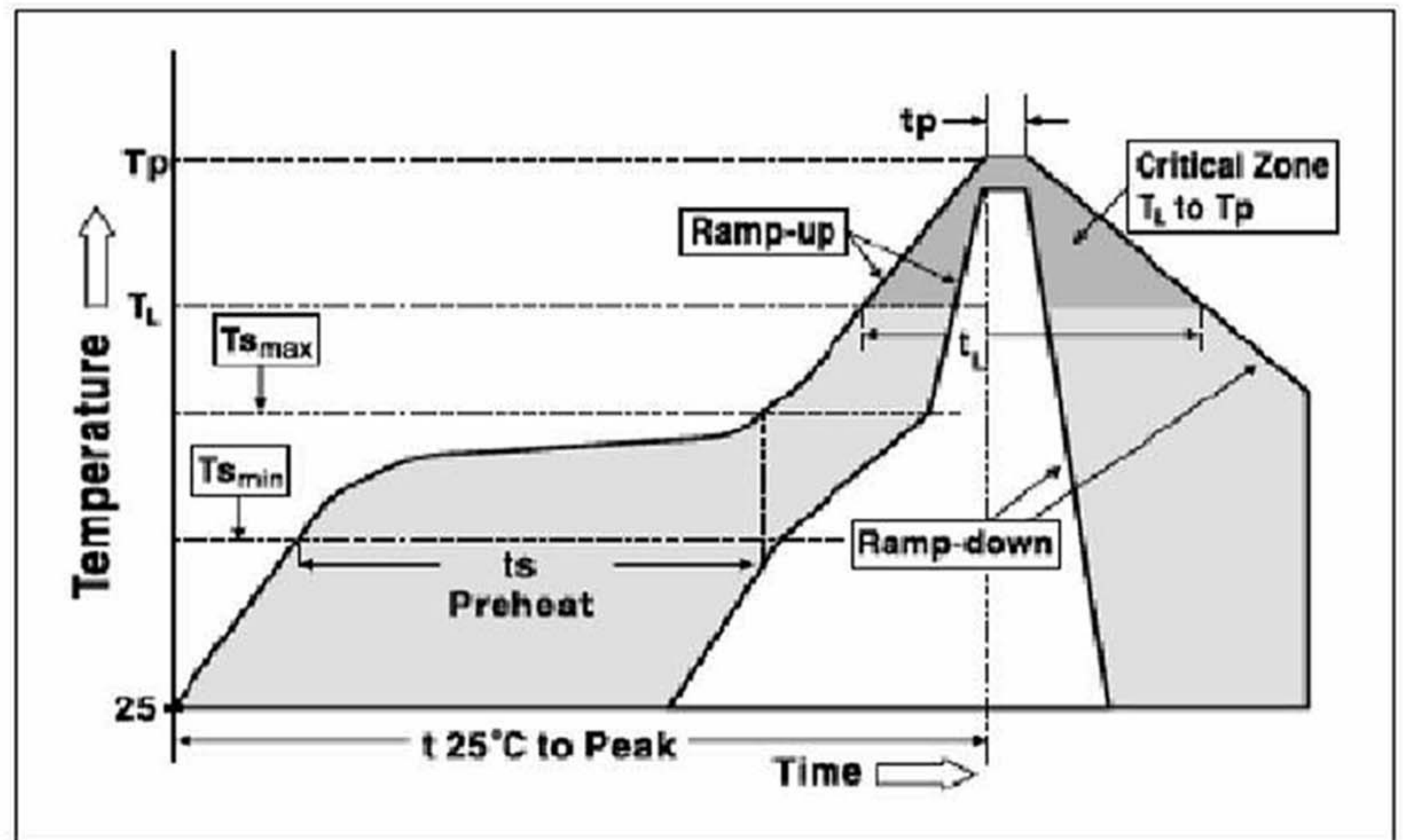

#### Solder Reflow

Due to "lead free / RoHS 6" construction of these PTC devices, the required Temperature and Dwell Time in the "Soldering" zone of the reflow profile are greater than those used for non-RoHS devices.

1. Recommended reflow methods ; IR, vapor phase oven, hot air oven.
2. Not Recommended For Wave Solder / Direct Immersion.
3. Recommended maximum paste thickness is 0.25mm.
4. Devices are compatible with standard industry cleaning solvents and methods.
5. MSL : 2a (According to IPC J-Std-020).

#### Caution

If reflow temperature / dwell times exceed the recommended profile, the electrical performance of the PTC may be affected.

Rework : MIL-STD-202G Method 210F, Test Condition A.

#### Standard Packaging

| Part Number                          | Tape/Reel Qty |
|--------------------------------------|---------------|
| OZCK0010FF2G<br>Thru<br>OZCK0035FF2G | 4,000         |
| OZCK0050FF2E<br>Thru<br>OZCK0100FF2E | 3,000         |

4000 or 3000 fuses in 7 inches dia. Reel, 8mm wide tape, 4mm pitch, per EIA-481(equivalent IEC-286 part 3).

#### P/N Explanation and Ordering Information

|  | OZCK  | OXXX | X | X | XX |
|--|-------|------|---|---|----|
| PTC series   | _____ |      |   |   |    |
| OZCK,0805 Size   | _____ |      |   |   |    |
| I HOLD Rating  | _____ |      |   |   |    |
| Refer to Part Number and IH Rating in Electrical Characteristics Table on P.1. |       |      |   |   |    |
| Electrical Characteristics   | _____ |      |   |   |    |
| F = Standard Design  |       |      |   |   |    |
| A to Z (except F) = Special, customer spec, DCR sort, etc.                     |       |      |   |   |    |
| Mechanical Features  | _____ |      |   |   |    |
| F = Standard Design  |       |      |   |   |    |
| A to Z (except F) = Special, customer spec, lead forming, etc.                 |       |      |   |   |    |
| Tape & Reel Qty  | _____ |      |   |   |    |
| See standard packaging   |       |      |   |   |    |

Specifications subject to change without notice



Bel Fuse Inc.  
206 Van Vorst Street  
Jersey City, NJ 07302 USA

+1 201.432.0463  
techhelp@belf.com  
[belfuse.com](http://belfuse.com)