

## **Metral 5 Row 1000 & 2000 Series Right Angle Receptacle Insertion Tooling**

The top tool is a modified “flat rock” press bar with side plates to support the ground shield during insertion.

The bottom tool serves as a board support during insertion and is cleared out in the areas that the tails come through the PCB.

### **Top Tool Press Bar 415754-5xx**

If all of the Metral modules that are to be inserted are stacked end to end you can use a standard press bar. If you have groups of Metral connectors and then a space other than an even increment of 12mm then you will need a custom top tool.

### **Standard Top Tools**

415754-502	2 (12mm) Modules
415754-503	3 (12mm) Modules
415754-504	4 (12mm) Modules
415754-505	5 (12mm) Modules
415754-506	6 (12mm) Modules
415754-507	7 (12mm) Modules
415754-508	8 (12mm) Modules
415754-509	9 (12mm) Modules
415754-510	10 (12mm) Modules
415754-511	11 (12mm) Modules
415754-512	12 (12mm) Modules
415754-513	13 (12mm) Modules
415754-514	14 (12mm) Modules
415754-515	15 (12mm) Modules
415754-516	16 (12mm) Modules
415754-517	17 (12mm) Modules
415754-518	18 (12mm) Modules
415754-519	19 (12mm) Modules
415754-520	20 (12mm) Modules
415754-521	21 (12mm) Modules

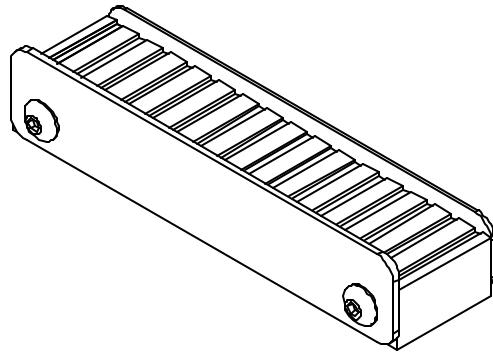

### **Board Supports (Bottom Tools) 162383-XXX**

Some Metral users prefer to develop their own board supports or use a PCB with oversized holes.

Either of these practices is acceptable but FCI also offers bottom tools for those customers who prefer factory tooling. The bottom tools can be cut to the length needed.

### **STANDARD BOTTOM TOOLS**

		Length
<b>162383-001</b>	146.8mm	5.780 inches
<b>162383-002</b>	194.8mm	7.669 inches
<b>162383-003</b>	302.8mm	11.921 inches
<b>162383-004</b>	457.2mm	18.000 inches
<b>162383-005</b>	609.6mm	24.000 inches

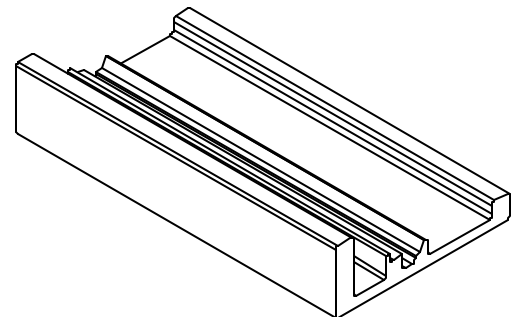

**MT-511 1000 Series Insertion Press P/N 166380-009 (110VAC)**

**MT-511 1000 Series Insertion Press P/N 166380-010 (220VAC)**

The MT-511-1000 Series Insertion Press is a semi-automatic bench top machine designed to terminate Metral Press Fit 1000 Series Right Angle Receptacles. The MT-511 1000 Series machine is pneumatically powered and electronically/pneumatically controlled. The MT-511 1000 Series Press can terminate Metral 1000 Series Press Fit Right Angle Receptacles one at a time or any number up to 12 modules (1 module = 5x6) per press cycle. The press has an adjustable pressure control to allow force adjustment from 1000 lbs to 8000 lbs.

The MT-511 1000 Series Press has the capability to terminate 1000 Series Metral connectors on a printed circuit board ranging in size from 4 inches (100 mm) x 18 inches (460 mm) up to 14 (360 mm) x 18 inches (460 mm).

In addition you must also purchase top tooling 415754 (previous page) that is the correct length for your application.

